



[www.uniqueworldedu.com](http://www.uniqueworldedu.com)

Dubai and Abu Dhabi

Contact us on Tel: +971 4 357 4415 Tel: +971 2 627 8480

■ India's First Medical and Engineering Entrance Coaching centre by Prof. **P.C THOMAS** now in UAE ■

Time : 3 hrs.

## Answers & Solutions

M.M. : 300

*for*

## JEE (MAIN)-2021 (Online) Phase-4

(Physics, Chemistry and Mathematics)

### IMPORTANT INSTRUCTIONS :

- (1) The test is of **3 hours** duration.
- (2) The Test Booklet consists of 90 questions. The maximum marks are 300.
- (3) There are **three** parts in the question paper A, B, C consisting of **Physics, Chemistry** and **Mathematics** having 30 questions in each part of equal weightage. Each part has two sections.
  - (i) Section-I : This section contains 20 multiple choice questions which have only one correct answer. Each question carries **4 marks** for correct answer and **-1 mark** for wrong answer.
  - (ii) Section-II : This section contains 10 questions. In Section-II, attempt any **five questions out of 10**. There will be **no negative marking for Section-II**. The answer to each of the questions is a numerical value. Each question carries **4 marks** for correct answer and there is no negative marking for wrong answer.

## PART-A : PHYSICS

### SECTION - I

**Multiple Choice Questions:** This section contains 20 multiple choice questions. Each question has 4 choices (1), (2), (3) and (4), out of which **ONLY ONE** is correct.

**Choose the correct answer :**

1. What equal length of an iron wire and a copper-nickel alloy wire, each of 2 mm diameter connected parallel to give an equivalent resistance of  $3 \Omega$  ?

(Given resistivities of iron and copper-nickel alloy wire are  $12 \mu\Omega \text{ cm}$  and  $51 \mu\Omega \text{ cm}$  respectively)

- (1) 110 m                      (2) 90 m  
(3) 97 m                      (4) 82 m

**Answer (3)**

**Sol.**  $\frac{1}{R_{\text{eq}}} = \frac{1}{R_1} + \frac{1}{R_2}$

$$\Rightarrow \frac{1}{3} = \frac{A}{\rho_i l} + \frac{A}{\rho_{\text{cu}} \times l}$$

$$\Rightarrow \frac{1}{3} = \frac{A}{l} \left[ \frac{1}{\rho_i} + \frac{1}{\rho_{\text{cu}}} \right]$$

$$\Rightarrow l = 3 \times \frac{\pi \times 4 \times 10^{-6}}{4} \left[ \frac{1}{12 \times 10^{-8}} + \frac{1}{51 \times 10^{-8}} \right]$$

$$= 96.97 \text{ m}$$

$$\approx 97 \text{ m}$$

2. The initial mass of a rocket is 1000 kg. Calculate at what rate the fuel should be burnt so that the rocket is given an acceleration of  $20 \text{ ms}^{-2}$ . The gases come out at a relative speed of  $500 \text{ ms}^{-1}$  with respect to the rocket: (Use  $g = 10 \text{ m/s}^2$ )

- (1)  $60 \text{ kg s}^{-1}$                       (2)  $10 \text{ kg s}^{-1}$   
(3)  $6.0 \times 10^2 \text{ kg s}^{-1}$                       (4)  $500 \text{ kg s}^{-1}$

**Answer (1)**

**Sol.** Here,  $M = 1000 \text{ kg}$ ,  $a = 20 \text{ m/s}^2$

$$V_{\text{rel}} = 500 \text{ m/s}$$

Using Newton's 2<sup>nd</sup> law,

$$V_{\text{rel}} \left( \frac{dm}{dt} \right) - Mg = Ma$$

$$\Rightarrow 500 \times \left( \frac{dm}{dt} \right) = 1000(10 + 20)$$

$$\Rightarrow \frac{dm}{dt} = 60 \text{ kg/s}$$

3. In a Screw Gauge, fifth division of the circular scale coincides with the reference line when the ratchet is closed. There are 50 divisions on the circular scale, and the main scale moves by 0.5 mm on a complete rotation. For a particular observation the reading on the main scale is 5 mm and the 20<sup>th</sup> division of the circular scale coincides with reference line. Calculate the true reading.

- (1) 5.20 mm                      (2) 5.00 mm  
(3) 5.25 mm                      (4) 5.15 mm

**Answer (4)**

**Sol.** Least count =  $\frac{0.5 \text{ mm}}{50} = 0.01 \text{ mm}$

$$\text{Zero error} = 5 \times 0.01 = 0.05 \text{ mm (positive)}$$

$$\text{True reading} = \text{Reading} - \text{Zero error}$$

$$= 5 \text{ mm} + 20 \times 0.01 - 0.05$$

$$= 5 + 15 \times 0.01$$

$$= 5.15 \text{ mm}$$

4. The material filled between the plates of a parallel plate capacitor has resistivity  $200 \Omega\text{m}$ . The value of capacitance of the capacitor is 2 pF. If a potential difference of 40 V is applied across the plates of the capacitor, then the value of leakage current flowing out of the capacitor is: (given the value of relative permittivity of material is 50)

- (1)  $9.0 \mu\text{A}$                       (2) 9.0 mA  
(3)  $0.9 \mu\text{A}$                       (4) 0.9 mA

**Answer (4)**

**Sol.** Here,  $C = \frac{K\epsilon_0 A}{d}$

$$\text{and } R = \frac{\rho d}{A}$$

$$\Rightarrow RC = \rho K\epsilon_0$$

$$\Rightarrow R = \frac{\rho K\epsilon_0}{C}$$

$$\text{So, } I = \frac{V}{R} = \frac{40 \times 2 \times 10^{-12}}{200 \times 50 \times 8.85 \times 10^{-12}}$$

$$= 0.9 \text{ mA}$$

5. Car B overtakes another car A at a relative speed of  $40 \text{ ms}^{-1}$ . How fast will the image of car B appear to move in the mirror of focal length 10 cm fitted in car A, when the car B is 1.9 m away from the car A?

- (1)  $0.2 \text{ ms}^{-1}$                       (2)  $0.1 \text{ ms}^{-1}$   
(3)  $4 \text{ ms}^{-1}$                       (4)  $40 \text{ ms}^{-1}$

**Answer (2)**

**Sol.** Here,  $\frac{1}{v} + \frac{1}{u} = \frac{1}{f} \Rightarrow \frac{1}{v} + \frac{1}{-190} = \frac{1}{10} \Rightarrow v = \frac{19}{2}$

$$\Rightarrow \left(\frac{dv}{dt}\right) = -\frac{v^2}{u^2} \left(\frac{du}{dt}\right)$$

$$\Rightarrow \left(\frac{dv}{dt}\right) = -\left(\frac{19}{2}\right)^2 \times 40$$

$$= -\frac{1}{400} \times 40 = 0.1 \text{ m/s}$$

6. Identify the logic operation carried out by the given circuit:

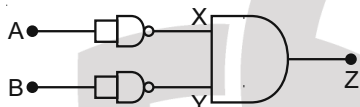

- (1) NOR  
(3) OR

- (2) AND  
(4) NAND

**Answer (1)**

**Sol.**

A	B	Z
1	1	0
0	0	1
1	0	0
0	1	0

NOR GATE

7. In a photoelectric experiment ultraviolet light of wavelength 280 nm is used with lithium cathode having work function  $\phi = 2.5 \text{ eV}$ . If the wavelength of incident light is switched to 400 nm, find out the change in the stopping potential.

$$(h = 6.63 \times 10^{-34} \text{ Js}, c = 3 \times 10^8 \text{ ms}^{-1})$$

- (1) 1.1 V                      (2) 0.6 V  
(3) 1.9 V                      (4) 1.3 V

**Answer (4)**

**Sol.**  $eV = \frac{hc}{\lambda} - \phi$

$$\Rightarrow e(V_1 - V_2) = (hc) \left[ \frac{1}{\lambda_1} - \frac{1}{\lambda_2} \right]$$

$$\Rightarrow e(V_1 - V_2) = 1.33$$

8. Two narrow bores of diameter 5.0 mm and 8.0 mm are joined together to form a U-shaped tube open at both ends. If this U-tube contains water, what is the difference in the level of two limbs of the tube?

[Take surface tension of water  $T = 7.3 \times 10^{-2} \text{ Nm}^{-1}$ , angle of contact = 0,  $g = 10 \text{ ms}^{-2}$  and density of water =  $1.0 \times 10^3 \text{ kg m}^{-3}$ ]

- (1) 2.19 mm                      (2) 3.62 mm  
(3) 5.34 mm                      (4) 4.97 mm

**Answer (1)**

**Sol.**  $\rho g \Delta H = \Delta P$

$$\Rightarrow \Delta H = \frac{\Delta P}{\rho g}$$

$$\Delta P = 2T \left( \frac{1}{R_1} - \frac{1}{R_2} \right)$$

$$\Rightarrow \Delta H = \frac{2T}{\rho g} \left( \frac{R_2 - R_1}{R_1 R_2} \right)$$

$$= \frac{2 \times 7.3 \times 10^{-2}}{1000 \times 10} \left( \frac{4 - 2.5}{4 \times 2.5 \times 10^{-3}} \right)$$

$$= 2.19 \text{ mm}$$

9. If E, L, M and G denote the quantities as energy, angular momentum, mass and constant of gravitation respectively, then the dimensions of P in the formula  $P = EL^2M^{-5}G^{-2}$  are:

- (1)  $[M^{-1}L^{-1}T^2]$                       (2)  $[M^1L^1T^{-2}]$   
(3)  $[M^0L^1T^0]$                       (4)  $[M^0L^0T^0]$

**Answer (4)**

**Sol.**  $[P] = [ML^2T^{-2}] [ML^2T^{-1}]^2 [M^{-5}] [M^{-1}L^3T^{-2}]^{-2}$   
 $= [M^0L^0T^0]$

10. The rms speeds of the molecules of hydrogen, Oxygen and Carbondioxide at the same temperature are  $V_H$ ,  $V_O$  and  $V_C$  respectively then:

- (1)  $V_H = V_O > V_C$                       (2)  $V_H = V_O = V_C$   
(3)  $V_C > V_O > V_H$                       (4)  $V_H > V_O > V_C$

**Answer (4)**

**Sol.**  $V_{rms} = \sqrt{\frac{3RT}{M}}$

$$V_{rms} \propto \frac{1}{\sqrt{M}} \text{ if } T \rightarrow \text{constant}$$

$$\Rightarrow V_H > V_{O_2} > V_{CO_2}$$

11. Inside a uniform spherical shell:
- the gravitational field is zero.
  - the gravitational potential is zero.
  - the gravitational field is same everywhere.
  - the gravitation potential is same everywhere.
  - all of the above

Choose the **most appropriate** answer from the options given below:

- (1) (e) only                      (2) (b), (c) and (d) only  
 (3) (a), (c) and (d) only      (4) (a), (b) and (c) only

**Answer (3)**

**Sol.** Gravitational field inside spherical shell = 0

If mass of spherical shell is M and radius is R, then gravitational potential at each point inside the shell

$$= \frac{-GM}{R}$$

12. An electric appliance supplies 600 J/min heat to the system. If the system delivers a power of 90 W. How long it would take to increase the internal energy by  $2.5 \times 10^3$  J?

- (1)  $2.5 \times 10^2$  s                      (2)  $2.4 \times 10^3$  s  
 (3)  $4.1 \times 10^1$  s                      (4)  $2.5 \times 10^1$  s

**Answer (1)**

**Sol.** Power, P = 6000 J/min

$$= \frac{6000 \text{ J}}{60} \text{ J/s} = 100 \text{ J/s}$$

Power of system = 90 W

Let time taken = t

So  $\Delta Q = 100t$ ,  $\Delta W = 90t$

Using  $\Delta Q = \Delta U + \Delta W$

$$\Rightarrow \Delta U = \Delta Q - \Delta W = 100t - 90t$$

$$2.5 \times 10^3 = 10t \Rightarrow t = 250 \text{ s}$$

13. The magnitude of vectors  $\vec{OA}$ ,  $\vec{OB}$  and  $\vec{OC}$  in the given figure are equal. The direction of  $\vec{OA} + \vec{OB} - \vec{OC}$  with x-axis will be

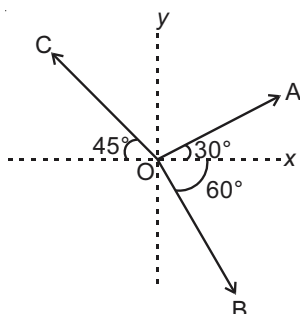

- (1)  $\tan^{-1} \left( \frac{1+\sqrt{3}-\sqrt{2}}{1-\sqrt{3}-\sqrt{2}} \right)$       (2)  $\tan^{-1} \left( \frac{\sqrt{3}-1+\sqrt{2}}{1+\sqrt{3}-\sqrt{2}} \right)$   
 (3)  $\tan^{-1} \left( \frac{\sqrt{3}-1+\sqrt{2}}{1-\sqrt{3}+\sqrt{2}} \right)$       (4)  $\tan^{-1} \left( \frac{1-\sqrt{3}-\sqrt{2}}{1+\sqrt{3}+\sqrt{2}} \right)$

**Answer (4)**

**Sol.** Sum of x component,

$$R_x = a \cos 30^\circ + a \cos 60^\circ + a \cos 45^\circ$$

$$= a \left( \frac{\sqrt{3}}{2} + \frac{1}{2} + \frac{1}{\sqrt{2}} \right)$$

$$= a \frac{\sqrt{3} + 1 + \sqrt{2}}{2}$$

Sum of y component,

$$R_y = a \sin 30^\circ - a \sin 60^\circ - a \sin 45^\circ$$

$$= \frac{a}{2} - \frac{a\sqrt{3}}{2} - \frac{a}{\sqrt{2}} = a \frac{1 - \sqrt{3} - \sqrt{2}}{2}$$

$$\text{Now, } \tan \theta = \frac{R_y}{R_x} = \frac{1 - \sqrt{3} - \sqrt{2}}{\sqrt{3} + 1 + \sqrt{2}}$$

$$\theta = \tan^{-1} \left( \frac{1 - \sqrt{3} - \sqrt{2}}{1 + \sqrt{3} + \sqrt{2}} \right)$$

14. An inductor coil stores 64 J of magnetic field energy and dissipates energy at the rate of 640 W when a current of 8 A is passed through it. If this coil is joined across an ideal battery, find the time constant of the circuit in seconds:

- (1) 0.4                                      (2) 0.8  
 (3) 0.2                                      (4) 0.125

**Answer (3)**

**Sol.** We know discharging of inductor

$$I = I_0 e^{-t/\tau}$$

$$U = \frac{1}{2} LI^2 \Rightarrow 64 = \frac{1}{2} LI^2 \quad \dots(i)$$

$$\text{Rate of loss of energy} = I^2 R$$

$$640 = I^2 R \quad \dots(ii)$$

from (i)/(ii)

$$\frac{64}{640} = \frac{\frac{1}{2} LI^2}{I^2 R}$$

$$\Rightarrow \frac{1}{10} = \frac{L}{2R} \Rightarrow \frac{L}{R} = 0.2$$

$$\Rightarrow \tau = 0.2$$

15. A particular hydrogen like ion emits radiation of frequency  $2.92 \times 10^{15}$  Hz when it makes transition from  $n = 3$  to  $n = 1$ . The frequency in Hz of radiation emitted in transition from  $n = 2$  to  $n = 1$  will be:

- (1)  $6.57 \times 10^{15}$                       (2)  $4.38 \times 10^{15}$   
 (3)  $2.46 \times 10^{15}$                       (4)  $0.44 \times 10^{15}$

**Answer (3)**

**Sol.** We know,  $\frac{1}{\lambda} = R_H Z^2 \left( \frac{1}{n_1^2} - \frac{1}{n_2^2} \right)$

$$\Rightarrow f = \frac{c}{\lambda} = Z^2 R_H C \left( \frac{1}{n_1^2} - \frac{1}{n_2^2} \right)$$

Now,  $2.92 \times 10^{15} = Z^2 R_H C \left( \frac{1}{1^2} - \frac{1}{3^2} \right)$  ... (i)

$f = Z^2 R_H C \left( \frac{1}{1^2} - \frac{1}{2^2} \right)$  ... (ii)

from (i)/(ii)

$$\frac{2.92 \times 10^{15}}{f} = \frac{\frac{8}{9}}{\frac{3}{4}} = \frac{8}{9} \times \frac{4}{3}$$

$$f = \frac{27}{32} \times 2.92 \times 10^{15} \text{ Hz}$$

$$= 2.46 \times 10^{15} \text{ Hz}$$

16. **Statement I:**

By doping silicon semiconductor with pentavalent material, the electrons density increases.

**Statement II:**

The n-type semiconductor has net negative charge.

In the light of the above statements, choose the **most appropriate** answer from the options given below:

- (1) Both statement I and statement II are true  
 (2) Both statement I and statement II are false  
 (3) Statement I is true but statement II is false  
 (4) Statement I is false but statement II is true

**Answer (3)**

**Sol.** Extra electron donated by pentavalent electron is available for conduction. So, statement I is correct but net charge is zero so statement II is false.

17. A solid metal sphere of radius  $R$  having charge  $q$  is enclosed inside the concentric spherical shell of inner radius  $a$  and outer radius  $b$  as shown in figure. The approximate variation electric field  $\vec{E}$  as a function of distance  $r$  from centre  $O$  is given by :

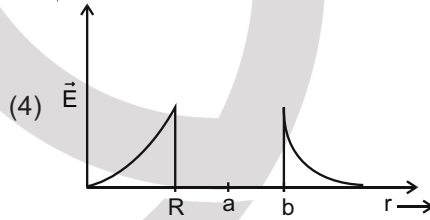
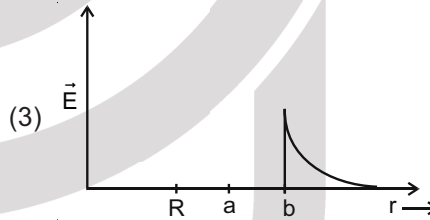
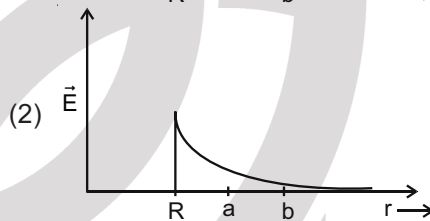
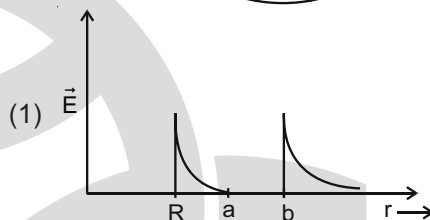
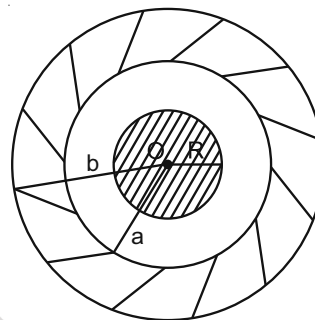

**Answer (1)**

**Sol.** Charge resides on the outer surface of metal surface.

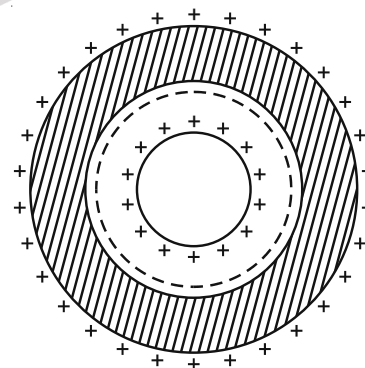

For  $0 \leq r \leq R$ ,  $E = 0$

$$E = \frac{Q}{4\pi\epsilon_0 r^2} \text{ for } R \leq r < a$$

$E = 0$  for  $a < r < b$

$$E = \frac{Q}{4\pi\epsilon_0 r^2} \text{ for } b < r$$

18. The fractional change in the magnetic field intensity at a distance 'r' from centre on the axis of current carrying coil of radius 'a' to the magnetic field intensity at the centre of the same coil is :

(Take  $r < a$ ).

(1)  $\frac{3r^2}{2a^2}$

(2)  $\frac{2a^2}{3r^2}$

(3)  $\frac{2r^2}{3a^2}$

(4)  $\frac{3a^2}{2r^2}$

**Answer (1)**

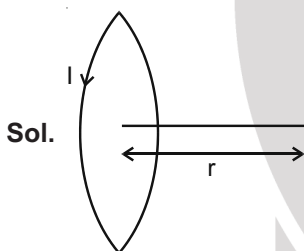

**Sol.**

$$B(r) = \frac{\mu_0 I a^2}{2(r^2 + a^2)^{3/2}}$$

$$B(r=0) = \frac{\mu_0 I}{2a}$$

$$\frac{\Delta B}{B} = \left[ \frac{\frac{\mu_0 I}{2a} - \frac{\mu_0 I a^2}{2(r^2 + a^2)^{3/2}}}{\frac{\mu_0 I}{2a}} \right]$$

$$\frac{\Delta B}{B} = 1 - \frac{a^3}{(r^2 + a^2)^{3/2}}$$

$$\frac{\Delta B}{B} = 1 - \left[ 1 + \frac{r^2}{a^2} \right]^{-3/2}$$

$$= \frac{3r^2}{2a^2}$$

19. A series LCR circuit driven by 300 V at a frequency of 50 Hz contains a resistance  $R = 3 \text{ k}\Omega$ , an inductor of inductive reactance  $X_L = 250\pi \Omega$  and an unknown capacitor. The value of capacitance to maximize the average power should be :

(take  $\pi^2 = 10$ )

(1)  $25 \mu\text{F}$

(2)  $4 \mu\text{F}$

(3)  $40 \mu\text{F}$

(4)  $400 \mu\text{F}$

**Answer (2)**

**Sol.** For power to be maximum

$$X_L = X_C$$

$$\omega L = \frac{1}{\omega C}$$

$$250\pi = \frac{1}{2\pi f \times C}$$

$$C = \frac{1}{2 \times 250 \times 50 \times \pi^2}$$

$$= \frac{1}{25000 \times 10}$$

$$C = 4 \mu\text{F}$$

20. In the given figure, the emf of the cell is 2.2 V and if internal resistance is  $0.6 \Omega$ . Calculate the power dissipated in the whole circuit :

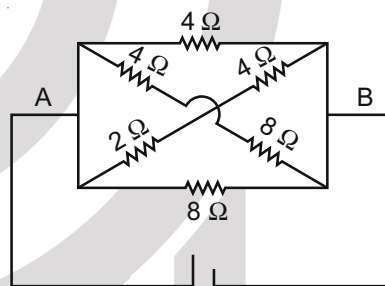

2.2 V,  $r = 0.6 \Omega$

(1) 1.32 W

(2) 4.4 W

(3) 2.2 W

(4) 0.65 W

**Answer (3)**

**Sol.** All the resistances are connected in parallel.

$$\frac{1}{R_{eq}} = \frac{1}{12} + \frac{1}{4} + \frac{1}{6} + \frac{1}{8}$$

$$= \frac{3}{12} + \frac{3}{8}$$

$$R_{eq} = \frac{8}{5} \Omega$$

$$I = \frac{2.2}{\left(\frac{8}{5} + 0.6\right)} = 1 \text{ A}$$

$$\text{Power} = I^2 R$$

$$= 2.2 \text{ W}$$

### SECTION - II

**Numerical Value Type Questions:** This section contains 10 questions. In Section II, attempt any five questions out of 10. The answer to each question is a **NUMERICAL VALUE**. For each question, enter the correct numerical value (in decimal notation, truncated/rounded-off to the second decimal place; e.g. 06.25, 07.00, -00.33, -00.30, 30.27, -27.30) using the mouse and the on-screen virtual numeric keypad in the place designated to enter the answer.

1. Two travelling waves produces a standing wave represented by equation.

$y = 1.0 \text{ mm} \cos(1.57 \text{ cm}^{-1})x \sin(78.5 \text{ s}^{-1})t$ . The node closest to the origin in the region

$x > 0$  will be at  $x = \underline{\hspace{2cm}}$  cm.

**Answer (1)**

**Sol.**  $k = 1.57 \text{ cm}^{-1}$

$$\Rightarrow \lambda = \frac{2\pi}{k} = 4 \text{ cm}$$

Closest node will be at a distance  $\lambda/4$  from  $x = 0$  (Antinode)

2. The short magnetic dipoles  $m_1$  and  $m_2$  each having magnetic moment of  $1 \text{ Am}^2$  are placed at point O P respectively. The distance between OP is 1 meter. The torque experienced by the magnetic dipole  $m_2$  due to the presence of  $m_1$  is  $\underline{\hspace{2cm}} \times 10^{-7} \text{ Nm}$ .

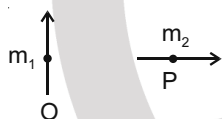

**Answer (1)**

**Sol.**  $\vec{\tau} = \vec{m}_2 \times \vec{B}_1$

$$\tau = m_2 \cdot \frac{\mu_0}{4\pi} \cdot \frac{m_1}{r^3} \cdot \sin 90^\circ$$

$$= 1 \times 10^{-7} \text{ N-m}$$

3. White light is passed through a double slit and interference is observed on a screen 1.5 m away. The separation between the slits is 0.3 mm. The first violet and red fringes are formed 2.0 mm and 3.5 away from the central white fringes. The difference in wavelengths of red and violet light is  $\underline{\hspace{2cm}}$  nm.

**Answer (300)**

**Sol.**  $Y_1 = \frac{D\lambda_1}{d}$

$$Y_2 = \frac{D\lambda_2}{d}$$

$$\lambda_2 - \lambda_1 = (Y_2 - Y_1) \frac{d}{D}$$

$$= 300 \text{ nm}$$

4. Two spherical balls having equal masses with radius of 5 cm each are thrown upwards along the same vertical direction at an interval of 3 s with the same initial velocity of 35 m/s, then these balls collide at a height of  $\underline{\hspace{2cm}}$  m. (take  $g = 10 \text{ m/s}^2$ )

**Answer (50)**

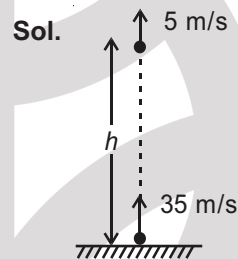

At the instant 2<sup>nd</sup> ball is thrown

$$h = 35 \times 3 - \frac{1}{2} \times 10 \times 3^2 = 60 \text{ m}$$

Balls will collide after time interval

$$= \frac{60}{35-5} = 2 \text{ second}$$

$$h' = 35 \times 2 - \frac{1}{2} \times 10 \times 2^2 = 50 \text{ m}$$

5. Consider a badminton racket with length scales as shown in the figure.

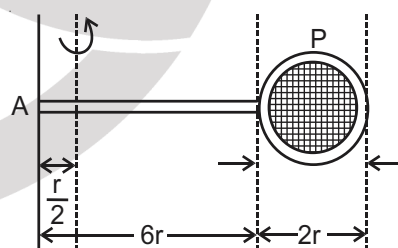

If the mass of the linear and circular portions of the badminton racket are same (M) and the mass of the threads are negligible, the moment of inertia of the racket about an axis perpendicular to the handle and in the plane of ring at,  $\frac{r}{2}$  distance from the end A of the handle will be  $\underline{\hspace{2cm}}$   $Mr^2$ .

**Answer (52)**

**Sol.**  $I = \left( \frac{1}{2} Mr^2 + M \left( \frac{13}{2} r \right)^2 \right) + \left( \frac{M(6r)^2}{12} + M \left( \frac{5}{2} r \right)^2 \right)$   
 $= Mr^2 \left( \frac{1}{2} + \frac{169}{4} + 3 + \frac{25}{4} \right) = 52 Mr^2$

6. The electric field in a plane electromagnetic wave is given by

$$\vec{E} = 200 \cos \left[ \left( \frac{0.5 \times 10^3}{\text{m}} \right) x - \left( 1.5 \times 10^{11} \frac{\text{rad}}{\text{s}} \times t \right) \right] \frac{\text{V}}{\text{m}} \hat{j}$$

If this wave falls normally on a perfectly reflecting surface having an area of  $100 \text{ cm}^2$ . If the radiation pressure exerted by the E.M. wave on the surface

during a 10 minute exposure is  $\frac{x}{10^9} \frac{\text{N}}{\text{m}^2}$ . Find the value of  $x$ .

**Answer (354)**

**Sol.**  $E_0 = 200$

$$I = \frac{1}{2} \epsilon_0 E_0^2 C$$

$$P = \frac{2I}{C} = \epsilon_0 E_0^2 = 8.85 \times 10^{-12} \times 4 \times 10^4$$

$$= 35.4 \times 10^{-8} = \frac{354}{10^9} \text{ N/m}^2$$

7. An amplitude modulated wave is represented by  $C_m(t) = 10 (1 + 0.2 \cos 12560t) \sin (111 \times 10^4 t)$  Volts. The modulating frequency in kHz will be \_\_\_\_\_.

**Answer (2)**

**Sol.**  $C_m(t) = 10 (1 + 0.2 \cos 12560t) \sin (111 \times 10^4 t)$

$$\text{Modulating frequency} = \frac{12560}{2\pi} = 2 \text{ kHz}$$

8. A source and a detector move away from each other in absence of wind with a speed of  $20 \text{ m/s}$  with respect to the ground. If the detector detects a frequency of  $1800 \text{ Hz}$  of the sound coming from the source, then the original frequency of source considering speed of sound in air  $340 \text{ m/s}$  will be \_\_\_\_\_ Hz.

**Answer (2025)**

**Sol.**  $v_{\text{app}} = v_0 \left( \frac{v - v_o}{v + v_s} \right)$

$$v_0 = v_{\text{app}} \times \left( \frac{v + v_s}{v - v_o} \right) = 1800 \times \frac{360}{320} = 2025$$

9. A soap bubble of radius  $3 \text{ cm}$  is formed inside the another soap bubble of radius  $6 \text{ cm}$ . The radius of an equivalent soap bubble which has the same excess pressure as inside the smaller bubble with respect to the atmospheric pressure is \_\_\_\_\_ cm.

**Answer (2)**

**Sol.**  $P_{\text{inside}}$  smaller bubble

$$= P_{\text{atm}} + \frac{4T}{R_{\text{out}}} + \frac{4T}{R_{\text{in}}}$$

$P_{\text{inside}}$  equivalent bubble

$$= P_{\text{atm}} + \frac{4T}{R_{\text{eq}}}$$

$$\Rightarrow \frac{1}{R_{\text{eq}}} = \frac{1}{R_{\text{out}}} + \frac{1}{R_{\text{in}}}$$

$$\Rightarrow R_{\text{eq}} = 2 \text{ cm}$$

10. A uniform chain of length  $3 \text{ meter}$  and mass  $3 \text{ kg}$  overhangs a smooth table with  $2 \text{ meter}$  laying on the table. If  $k$  is the kinetic energy of the chain in Joule as it completely slips off the table, then the value of  $k$  is \_\_\_\_\_.

(Take  $g = 10 \text{ m/s}^2$ )

**Answer (40)**

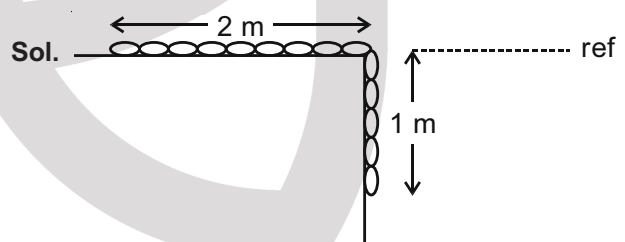

$$P.E._{\text{initial}} = -\frac{m}{3} \times \frac{\ell}{3} \times \frac{1}{2} g = \frac{-mg\ell}{18}$$

$$P.E._{\text{final}} = -m \frac{\ell}{2} g = -\frac{mg\ell}{2}$$

$$K.E._{\text{final}} = \frac{1}{2} mv^2$$

$$\Rightarrow \frac{1}{2} mv^2 = \frac{4}{9} \times m \times \ell \times g$$

$$\Rightarrow \frac{1}{2} mv^2 = 40 \text{ J}$$

## PART-B : CHEMISTRY

### SECTION - I

**Multiple Choice Questions:** This section contains 20 multiple choice questions. Each question has 4 choices (1), (2), (3) and (4), out of which **ONLY ONE** is correct.

**Choose the correct answer :**

1. Given below are two statements :

Statement I : Frenkel defects are vacancy as well as interstitial defects.

Statement II : Frenkel defect leads to colour in ionic solids due to presence of F-centres.

Choose the **most appropriate** answer for the statements from the options given below :

- (1) Statement I is true but Statement II is false
- (2) Both Statement I and Statement II are true
- (3) Statement I is false but Statement II is true
- (4) Both Statement I and Statement II are false

**Answer (1)**



**Sol. Frenkel Defect :** This defect is shown by ionic solids. The smaller ion (usually cation) is dislocated from its normal site to an interstitial site.

It creates a vacancy defect at its original site and an **interstitial defect** at its new location.

F-centre is formed in metal excess defect which is a non-stoichiometric defect.

2. The major product formed in the following reaction is :

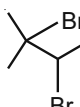

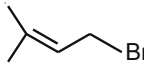
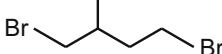
- (1) 
- (2) 
- (3) 
- (4) 

**Answer (3)**

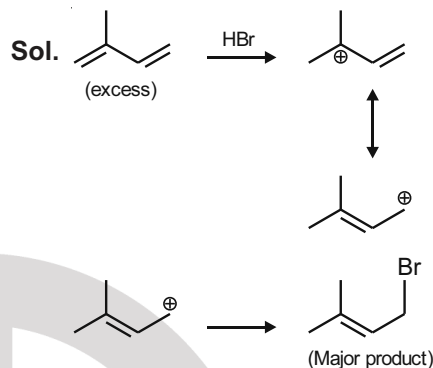

3. The correct options for the products A and B of the following reactions are :

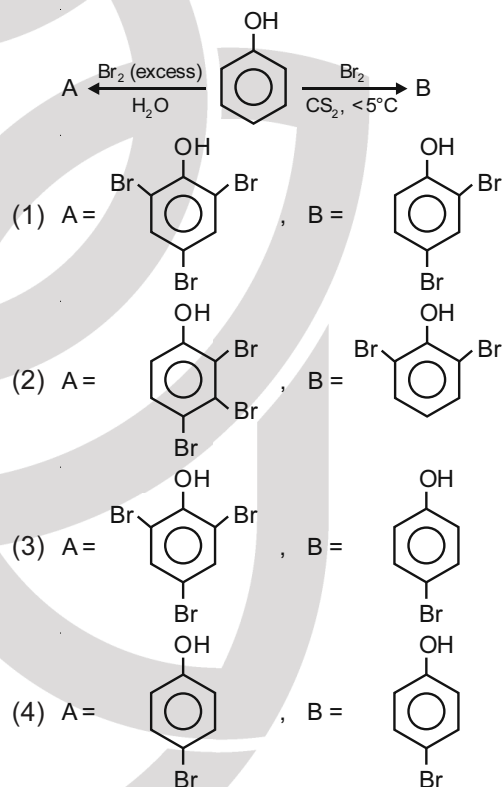

**Answer (3)**

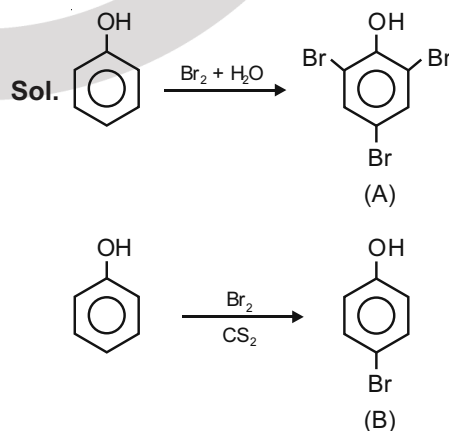

4. Given below are two statements :

**Statement I :** According to Bohr's model of an atom, qualitatively the magnitude of velocity of electron increases with decrease in positive charges on the nucleus as there is no strong hold on the electron by the nucleus.

**Statement II :** According to Bohr's model of an atom, qualitatively the magnitude of velocity of electron increases with decrease in principal quantum number.

In the light of the above statements, choose the **most appropriate** answer from the options given below :

- (1) Both **Statement I** and **Statement II** are false
- (2) **Statement I** is false but **Statement II** is true
- (3) Both **Statement I** and **Statement II** are true
- (4) **Statement I** is true but **Statement II** is false

**Answer (2)**

**Sol.**  $v_n = 2.18 \times 10^6 \times \frac{Z}{n} \text{ m/s}$

Qualitatively the magnitude of velocity of electron increases with increase of positive charge on the nucleus and decreases with increase of principal quantum number.

5. The major products formed in the following reaction sequence **A** and **B** are

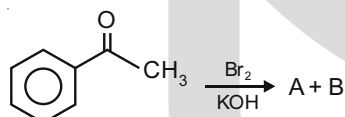

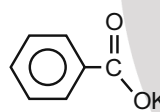
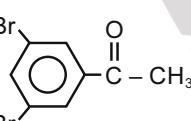
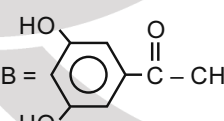
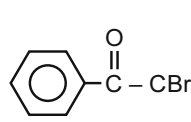
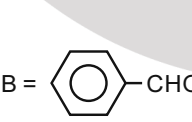
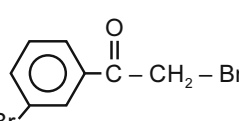
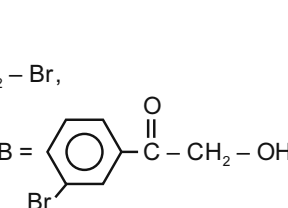
- (1) A = , B =  $\text{CHBr}_3$
- (2) A = , B = 
- (3) A = , B = 
- (4) A = , B = 

**Answer (1)**

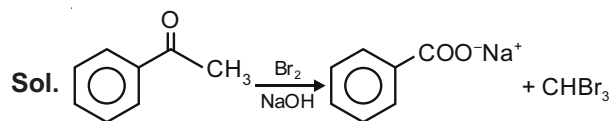

6. The conversion of hydroxyapatite occurs due to presence of  $\text{F}^-$  ions in water. The correct formula of hydroxyapatite is :

- (1)  $[\text{3Ca}(\text{OH})_2 \cdot \text{CaF}_2]$
- (2)  $[\text{3Ca}_3(\text{PO}_4)_2 \cdot \text{Ca}(\text{OH})_2]$
- (3)  $[\text{3Ca}_3(\text{PO}_4)_2 \cdot \text{CaF}_2]$
- (4)  $[\text{Ca}_3(\text{PO}_4)_2 \cdot \text{CaF}_2]$

**Answer (2)**

**Sol.** The correct formula of hydroxyapatite is  $[\text{3Ca}_3(\text{PO}_4)_2 \cdot \text{Ca}(\text{OH})_2]$ .

7. Which one of the following when dissolved in water gives coloured solution in nitrogen atmosphere?

- (1)  $\text{AgCl}$
- (2)  $\text{Cu}_2\text{Cl}_2$
- (3)  $\text{ZnCl}_2$
- (4)  $\text{CuCl}_2$

**Answer (4)**

**Sol.**  $\text{CuCl}_2$  in water gives blue solution.

8. Given below are two statements :

**Statement I :** In the titration between strong acid and weak base methyl orange is suitable as an indicator.

**Statement II :** For titration of acetic acid with  $\text{NaOH}$  phenolphthalein is not a suitable indicator.

In the light of the above statements, choose the most appropriate answer from the options given below :

- (1) **Statement I** is false but **Statement II** is true
- (2) **Statement I** is true but **Statement II** is false
- (3) Both **Statement I** and **Statement II** are false
- (4) Both **Statement I** and **Statement II** are true

**Answer (2)**

**Sol.** Statement I is true whereas statement II is false.

Titration of strong acid and weak base uses methyl orange as indicator.

For titration of weak acid and strong base, phenolphthalein is a suitable indicator.

9. The correct sequential addition of reagents in the preparation of 3-nitrobenzoic acid from benzene is :

- (1)  $\text{HNO}_3/\text{H}_2\text{SO}_4$ ,  $\text{Br}_2/\text{AlBr}_3$ ,  $\text{Mg}/\text{ether}$ ,  $\text{CO}_2$ ,  $\text{H}_3\text{O}^+$
- (2)  $\text{Br}_2/\text{AlBr}_3$ ,  $\text{HNO}_3/\text{H}_2\text{SO}_4$ ,  $\text{Mg}/\text{ether}$ ,  $\text{CO}_2$ ,  $\text{H}_3\text{O}^+$
- (3)  $\text{Br}_2/\text{AlBr}_3$ ,  $\text{NaCN}$ ,  $\text{H}_3\text{O}^+$ ,  $\text{HNO}_3/\text{H}_2\text{SO}_4$
- (4)  $\text{Br}_2/\text{AlBr}_3$ ,  $\text{HNO}_3/\text{H}_2\text{SO}_4$ ,  $\text{NaCN}$ ,  $\text{H}_3\text{O}^+$

**Answer (1)**

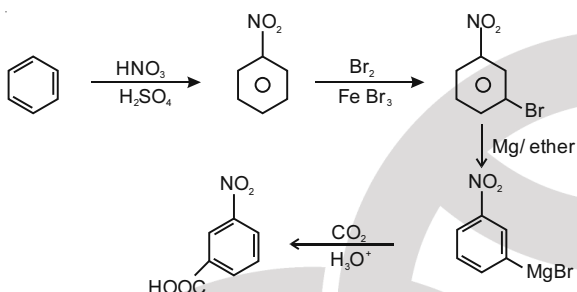

**Sol.**

10. The **incorrect** statement is :

- (1)  $\text{F}_2$  is more reactive than  $\text{ClF}$ .
- (2)  $\text{F}_2$  is a stronger oxidizing agent than  $\text{Cl}_2$  in aqueous solution.
- (3) On hydrolysis  $\text{ClF}$  forms  $\text{HOCl}$  and  $\text{HF}$ .
- (4)  $\text{Cl}_2$  is more reactive than  $\text{ClF}$ .

**Answer (4)**

**Sol.** In general, interhalogen compounds are more reactive than halogens (except fluorine). This is because  $\text{X-X'}$  bond in interhalogens is weaker than  $\text{X-X}$  bond in halogens except  $\text{F-F}$  bond.

All these undergo hydrolysis giving halide ion derived from the smaller halogen and a hypohalite (when  $\text{XX}'$ ), halite (when  $\text{XX}'_3$ ), halate (when  $\text{XX}'_5$ ) and perchalate (when  $\text{XX}'_7$ ) anion derived from the larger halogen.

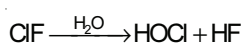
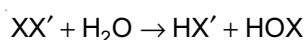

Fluorine oxidises water to oxygen whereas chlorine and bromine react with water to form corresponding hydrohalic and hypohalous acids.

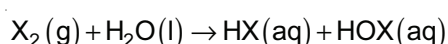
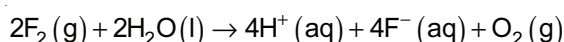

(where  $\text{X} = \text{Cl}$  or  $\text{Br}$ )

11. What are the products formed in sequence when excess of  $\text{CO}_2$  is passed in slaked lime?

- (1)  $\text{CaO}$ ,  $\text{CaCO}_3$
- (2)  $\text{CaCO}_3$ ,  $\text{Ca}(\text{HCO}_3)_2$
- (3)  $\text{Ca}(\text{HCO}_3)_2$ ,  $\text{CaCO}_3$
- (4)  $\text{CaO}$ ,  $\text{Ca}(\text{HCO}_3)_2$

**Answer (2)**

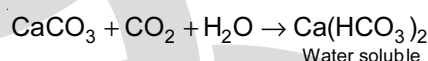
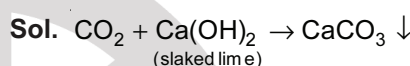

12. Which one of the following is correct for the adsorption of a gas at a given temperature on a solid surface?

- (1)  $\Delta H < 0$ ,  $\Delta S < 0$
- (2)  $\Delta H > 0$ ,  $\Delta S < 0$
- (3)  $\Delta H > 0$ ,  $\Delta S > 0$
- (4)  $\Delta H < 0$ ,  $\Delta S > 0$

**Answer (1)**

**Sol.** For adsorption of gas

$$\Delta H < 0$$

$$\Delta S < 0$$

During adsorption, there is always a decrease in residual forces of the surface, i.e., there is decrease in surface energy which appears as heat. Adsorption, therefore, is invariably an exothermic process. In other words,  $\Delta H$  of adsorption is always negative. When a gas is adsorbed, the freedom of movement of its molecules become restricted. This amounts to decrease in the entropy of the gas after adsorption, i.e.,  $\Delta S$  is negative. Adsorption is thus accompanied by decrease in enthalpy as well as decrease in entropy of the system.

13. Given below are two statements :

**Statement I :** The limiting molar conductivity of KCl (strong electrolyte) is higher compared to that of CH<sub>3</sub>COOH (weak electrolyte).

**Statement II :** Molar conductivity decreases with decrease in concentration of electrolyte.

In the light of the above statements, choose the most appropriate answer from the options given below :

- (1) Statement I is true but Statement II is false
- (2) Both Statement I and Statement II are false
- (3) Both Statement I and Statement II are true
- (4) Statement I is false but Statement II is true

**Answer (2)**

**Sol.**

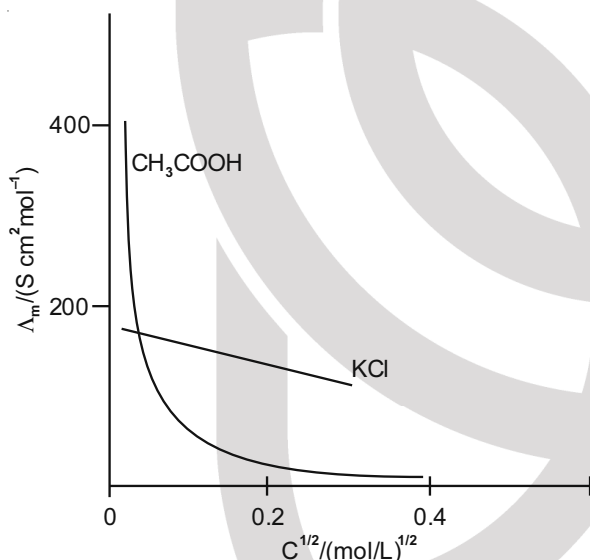

$$\Lambda_m^\infty(\text{CH}_3\text{COOH}) = \lambda_m^\infty(\text{CH}_3\text{COO}^-) + \lambda_m^\infty(\text{H}^+)$$

Molar conductivity increases with decrease in concentration. This is because the total volume, V, of solution containing one mole of electrolyte also increases. It has been found that decrease in k on dilution of a solution is more than compensated by increase in its volume.

14. The polymer formed on heating Novolac with formaldehyde is :

- (1) Melamine
- (2) Nylon 6, 6
- (3) Bakelite
- (4) Polyester

**Answer (3)**

**Sol.** Novolac on heating with formaldehyde undergoes cross linking to form an infusible solid mass called bakelite. It is thermosetting polymer which cannot be reused or remoulded. Thus, bakelite is formed by cross linking of linear chains of the polymer novolac.

15. Excess of isobutane on reaction with Br<sub>2</sub> in presence of light at 125°C gives which one of the following, as the major product?

- (1)  $\text{CH}_3 - \overset{\text{CH}_3}{\underset{\text{CH}_3}{\text{C}}} - \text{Br}$
- (2)  $\text{CH}_3 - \underset{\text{CH}_3}{\text{CH}} - \text{CH}_2\text{Br}$
- (3)  $\text{CH}_3 - \overset{\text{Br}}{\underset{\text{CH}_3}{\text{C}}} - \text{CH}_2 - \text{Br}$
- (4)  $\text{CH}_3 - \underset{\text{CH}_2\text{Br}}{\text{CH}} - \text{CH}_2\text{Br}$

**Answer (1)**

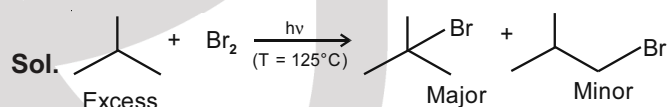

Bromination is highly selective, reactivity order – 3° >> 2° > 1

16. Given below are two statements.

**Statement I :** The choice of reducing agents for metals extraction can be made by using Ellingham diagram, a plot of ΔG vs temperature.

**Statement II :** The value of ΔS increases from left to right in Ellingham diagram.

In the light of the above statements, choose the most appropriate answer from the options given below:

- (1) Both Statement I and Statement II are true
- (2) Both Statement I and Statement II are false
- (3) Statement I is false but Statement II is true
- (4) Statement I is true but Statement II is false

**Answer (4)**

**Sol.** In a number of processes, one metal is used to reduce the oxide of another metal. Any metal will reduce the oxide of other metals which lie above it in the Ellingham diagram because the free energy will become more negative by an amount equal to the difference between the two graphs at that particular temperature.

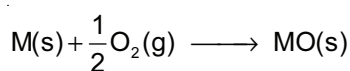

entropy of reaction decreases

17. Which one of the following complexes is violet in colour?

- (1)  $[Fe(SCN)_6]^{4-}$
- (2)  $[Fe(CN)_5NOS]^{4-}$
- (3)  $[Fe(CN)_6]^{4-}$
- (4)  $Fe_4[Fe(CN)_6]_3 \cdot H_2O$

**Answer (2)**

- Sol.**  $[Fe(CN)_6]^{4-}$  – Pale yellow  
 $[Fe(CN)_6]^{3-}$  – Yellow  
 $Fe(SCN)_3$  – Red colouration  
 $[Fe(CN)_5(NOS)]^{4-}$  – Violet colour

18. The major product formed in the following reaction is

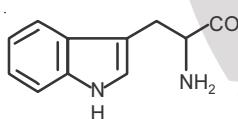
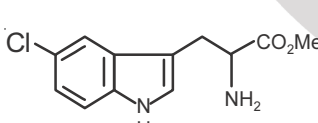
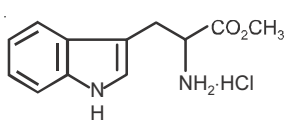
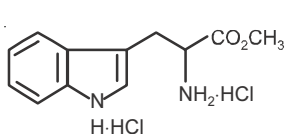

- (1) 
- (2) 
- (3) 
- (4) 

**Answer (3)**

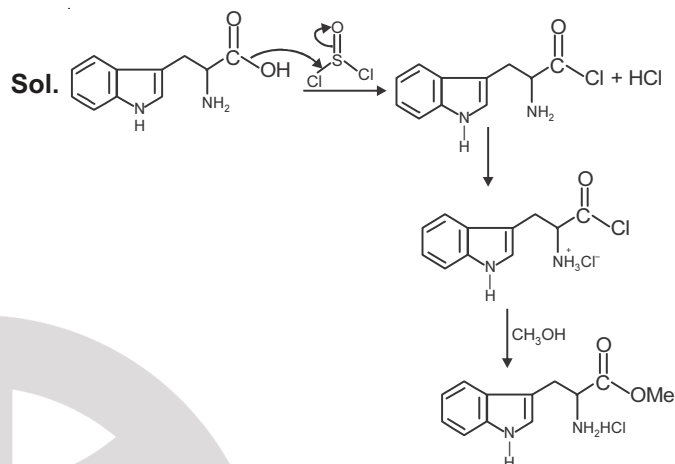

19. Which one of the following methods is most suitable for preparing deionized water?

- (1) Synthetic resin method
- (2) Permutit method
- (3) Clark's method
- (4) Calgon's method

**Answer (1)**

**Sol.** Synthetic resin method is most suitable for preparing deionized water.

**Synthetic resins method:** Nowadays hard water is softened by using synthetic cation exchangers. This method is more efficient than zeolite process. Cation exchange resins contain large organic molecule with  $-SO_3H$  group and are water insoluble. Ion exchange resin ( $RSO_3H$ ) is changed to  $RNa$  by treating it with  $NaCl$ . The resin exchanges  $Na^+$  ions with  $Ca^{2+}$  and  $Mg^{2+}$  ions present in hard water to make the water soft. Here R is resin anion.

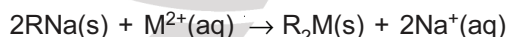

The resin can be regenerated by adding aqueous  $NaCl$  solution.

Pure de-mineralised (de-ionized) water free from all soluble mineral salts is obtained by passing water successively through a cation exchange (in the  $H^+$  form) and an anion - exchange (in the  $OH^-$  form) resins:

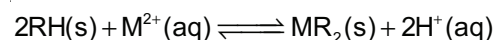

In this cation exchange process,  $H^+$  exchanges for  $Na^+$ ,  $Ca^{2+}$ ,  $Mg^{2+}$  and other cations present in water. This process results in proton release and thus makes the water acidic.

20. Among the following compounds I-IV, which one forms a yellow precipitate on reacting sequentially with (i) NaOH (ii) dil. HNO<sub>3</sub> (iii) AgNO<sub>3</sub>?

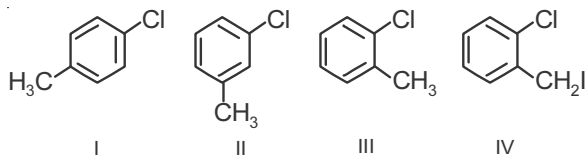

- (1) III  
(2) II  
(3) IV  
(4) I

**Answer (3)**

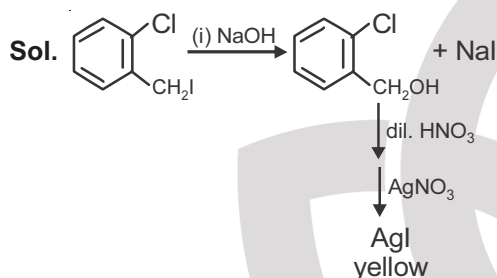

### SECTION - II

**Numerical Value Type Questions:** This section contains 10 questions. In Section II, attempt any five questions out of 10. The answer to each question is a **NUMERICAL VALUE**. For each question, enter the correct numerical value (in decimal notation, truncated/rounded-off to the second decimal place; e.g. 06.25, 07.00, -00.33, -00.30, 30.27, -27.30) using the mouse and the on-screen virtual numeric keypad in the place designated to enter the answer.

1. The ratio of number of water molecules in Mohr's salt and potash alum is \_\_\_\_\_  $\times 10^{-1}$ . (Integer answer)

**Answer (5)**

**Sol.** Mohr salt  $(\text{NH}_4)_2\text{Fe}(\text{SO}_4)_2 \cdot 6\text{H}_2\text{O}$

Potash alum  $\text{KAl}(\text{SO}_4)_2 \cdot 12\text{H}_2\text{O}$

$$\text{Ratio} = \frac{6}{12} = 0.5 = 5 \times 10^{-1}$$

2. The Born-Haber cycle for KCl is evaluated with the following data:

$$\Delta_f H^\ominus \text{ for KCl} = -436.7 \text{ kJ mol}^{-1}; \Delta_{\text{sub}} H^\ominus \text{ for K} = 89.2 \text{ kJ mol}^{-1};$$

$$\Delta_{\text{ionization}} H^\ominus \text{ for K} = 419.0 \text{ kJ mol}^{-1}; \Delta_{\text{electron gain}} H^\ominus \text{ for Cl}_{(g)} = -348.6 \text{ kJ mol}^{-1};$$

$$\Delta_{\text{bond}} H^\ominus \text{ for Cl}_2 = 243.0 \text{ kJ mol}^{-1}$$

The magnitude of lattice enthalpy of KCl in  $\text{kJ mol}^{-1}$  is \_\_\_\_\_. (Nearest integer)

**Answer (718)**

**Sol.** Born-Haber cycle of KCl is

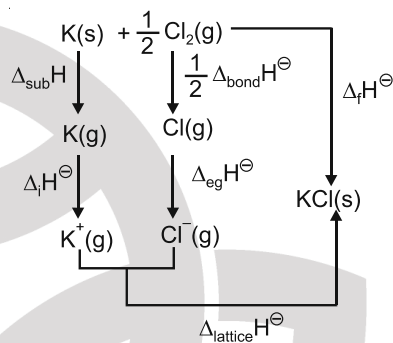

$$\Delta_{\text{sub}} H + \Delta_f H^\ominus + \frac{1}{2} \Delta_{\text{bond}} H^\ominus + \Delta_{\text{eg}} H^\ominus + \Delta_{\text{lattice}} H^\ominus$$

$$= \Delta_f H^\ominus$$

$$89.2 + 419.0 + \frac{1}{2} (243.0) - 348.6 + \Delta_{\text{lattice}} H^\ominus$$

$$= -436.7$$

$$\Delta_{\text{lattice}} H^\ominus = -717.8 \text{ kJ/mol}$$

3. The OH<sup>-</sup> concentration in a mixture of 5.0 mL of 0.0504 M NH<sub>4</sub>Cl and 2 mL of 0.0210 M NH<sub>3</sub> solution is  $x \times 10^{-6}$  M. The value of x is \_\_\_\_\_. (Nearest integer)

$$[\text{Given } K_w = 1 \times 10^{-14} \text{ and } K_b = 1.8 \times 10^{-5}]$$

**Answer (3)**

**Sol.**  $\text{NH}_3 + \text{H}_2\text{O} \rightleftharpoons \text{NH}_4^+ + \text{OH}^-$

$$= 2 \times 0.0210 = 0.042 \text{ mmol}$$

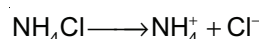

$$= 5 \times 0.0504 = 0.252 \text{ mmol}$$

$$p^{\text{OH}} = pK_b + \log \frac{[\text{Salt}]}{[\text{Base}]}$$

$$p^{OH} = -\log(1.8 \times 10^{-5}) + \log\left(\frac{0.252}{0.042}\right)$$

$$= 4.74 + 0.77$$

$$p^{OH} = 5.51$$

$$[OH^-] = 10^{-5.51}$$

$$= 3.09 \times 10^{-6}$$

$$\approx 3 \times 10^{-6}$$

4. The total number of negative charge in the tetrapeptide, Gly-Glu-Asp-Tyr, at pH 12.5 will be \_\_\_\_\_. (Integer answer)

**Answer (4)**

**Sol.** Gly-Glu-Asp-Tyr

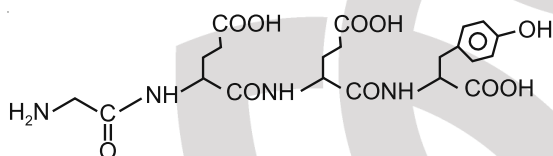

At pH = 12.5

—COOH, and phenol will lose its proton

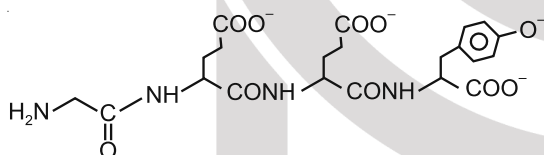

5. Of the following four aqueous solutions, total number of those solutions whose freezing point is lower than that of 0.10 M C<sub>2</sub>H<sub>5</sub>OH is \_\_\_\_\_. (Integer answer)

- (i) 0.10 M Ba<sub>3</sub>(PO<sub>4</sub>)<sub>2</sub>
- (ii) 0.10 M Na<sub>2</sub>SO<sub>4</sub>
- (iii) 0.10 M KCl
- (iv) 0.10 M Li<sub>3</sub>PO<sub>4</sub>

**Answer (4)**

**Sol.** i for C<sub>2</sub>H<sub>5</sub>OH is 1.

$$\Delta T_f = i k_f m$$

$$\Delta T_f \propto i \text{ (considering molarity = molality)}$$

$$\text{Ba}_3(\text{PO}_4)_2 \quad i = 5$$

$$\text{Na}_2\text{SO}_4 \quad i = 3$$

$$\text{KCl} \quad i = 2$$

$$\text{Li}_3\text{PO}_4 \quad i = 4$$

6. AB<sub>3</sub> is an interhalogen T-shaped molecule. The number of lone pairs of electrons on A is \_\_\_\_\_. (Integer answer)

**Answer (2)**

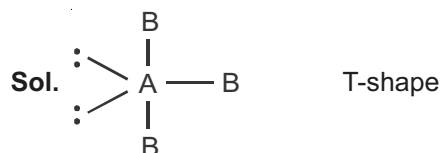

An interhalogen compound.

7. An aqueous KCl solution of density 1.20 g ml<sup>-1</sup> has a molality of 3.30 mol kg<sup>-1</sup>. The molarity of the solution in mol L<sup>-1</sup> is \_\_\_\_\_. (Nearest integer)

[Molar mass of KCl = 74.5]

**Answer (3)**

**Sol.** Molar mass of KCl = 39 + 35.5  
= 74.5 g mol<sup>-1</sup>

Density of solution = 1.20 g ml<sup>-1</sup>

Mass of solution = 1000 + 3.3 × 74.5

= 1245.85 g

Volume of solution =  $\frac{1245.85}{1.2}$  ml

= 1038.20 ml

Molarity =  $\frac{3.3 \times 1000}{1038.20} = 3.17 \text{ mol/l} \approx 3$

8. The following data was obtained for chemical reaction given below at 975 K.



[NO]	[H <sub>2</sub> ]	Rate
mol L <sup>-1</sup>	mol L <sup>-1</sup>	mol L <sup>-1</sup> s <sup>-1</sup>
(A) 8 × 10 <sup>-5</sup>	8 × 10 <sup>-5</sup>	7 × 10 <sup>-9</sup>
(B) 24 × 10 <sup>-5</sup>	8 × 10 <sup>-5</sup>	2.1 × 10 <sup>-8</sup>
(C) 24 × 10 <sup>-5</sup>	32 × 10 <sup>-5</sup>	8.4 × 10 <sup>-8</sup>

The order of the reaction with respect to NO is \_\_\_\_\_. (Integer answer)

**Answer (1)**

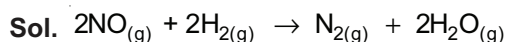

$$\text{Rate} = k[\text{NO}]^x [\text{H}_2]^y$$

$$7 \times 10^{-9} = k(8 \times 10^{-5})^x (8 \times 10^{-5})^y \quad \dots(\text{i})$$

$$2.1 \times 10^{-8} = k(24 \times 10^{-5})^x (8 \times 10^{-5})^y \quad \dots(\text{ii})$$

Now dividing (ii) by (i)

$$\frac{2.1 \times 10^{-8}}{7 \times 10^{-9}} = \left( \frac{24 \times 10^{-5}}{8 \times 10^{-5}} \right)^x$$

$$3 = 3^x$$

$$\Rightarrow x = 1$$

Similarly,

$$\frac{8.4 \times 10^{-8}}{2.1 \times 10^{-8}} = \left( \frac{32 \times 10^{-5}}{8 \times 10^{-5}} \right)^y$$

$$\Rightarrow y = 1$$

Order of reaction w.r.t. NO is 1.

9. These are physical properties of an element

- (A) Sublimation enthalpy
- (B) Ionisation enthalpy
- (C) Hydration enthalpy
- (D) Electron gain enthalpy

The total number of above properties that affect the reduction potential is \_\_\_\_\_. (Integer answer)

**Answer (3\*)**

**Sol.** The standard electrode potential ( $E^\ominus$ ) which measures the reducing power represents the overall change :

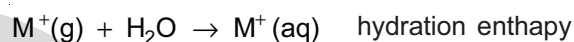
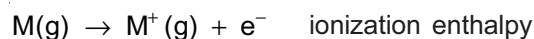

The factors which affects the reducing potential of an element is sublimation enthalpy, ionization enthalpy and hydration enthalpy.

10. The number of 4f electrons in the ground state electronic configuration of  $\text{Gd}^{2+}$  is \_\_\_\_\_. [Atomic number of Gd = 64]

**Answer (7)**

**Sol.** Atomic number of Gd is 64

Electronic configuration of Gd is  $[\text{Xe}]4f^7 5d^1 6s^2$

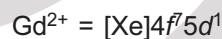

**PART-C : MATHEMATICS**
**SECTION - I**

**Multiple Choice Questions:** This section contains 20 multiple choice questions. Each question has 4 choices (1), (2), (3) and (4), out of which **ONLY ONE** is correct.

**Choose the correct answer :**

1. Let ABC be a triangle with A(-3, 1) and  $\angle ACB = \theta$ ,  $0 < \theta < \frac{\pi}{2}$ . If the equation of the median through B is  $2x + y - 3 = 0$  and the equation of angle bisector of C is  $7x - 4y - 1 = 0$ , then  $\tan \theta$  is equal to

- (1) 2 (2)  $\frac{3}{4}$   
(3)  $\frac{4}{3}$  (4)  $\frac{1}{2}$

**Answer (3)**

**Sol.**  $E\left(\frac{x_3 - 3}{2}, \frac{y_3 + 1}{2}\right)$  lies on  $2x + y - 3 = 0$

$$\Rightarrow 2\left(\frac{x_3 - 3}{2}\right) + \frac{y_3 + 1}{2} - 3 = 0$$

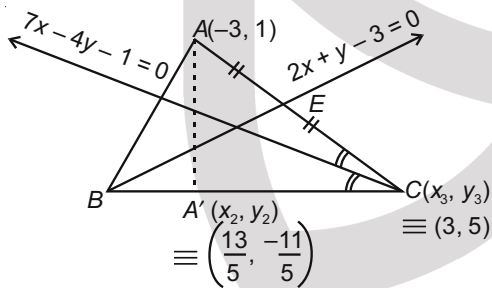

$$\Rightarrow 2x_3 + y_3 - 11 = 0 \quad \dots(i)$$

$C(x_3, y_3)$  lies on  $7x - 4y - 1 = 0$

$$\therefore 7x_3 - 4y_3 - 1 = 0 \quad \dots(ii)$$

$$(i) \& (ii) \Rightarrow C \equiv (x_3, y_3) \equiv (3, 5)$$

$A'(x_2, y_2)$  is image of A and is given by

$$\frac{x_2 + 3}{7} = \frac{y_2 - 1}{-4} = -2 \left( \frac{7(-3) - 4(1) - 1}{7^2 + (-4)^2} \right) = \frac{4}{5}$$

$$\Rightarrow A' \equiv (x_2, y_2) \equiv \left( \frac{13}{5}, -\frac{11}{5} \right)$$

$$m_{AC} = m_1 = \frac{5 - 1}{3 - (-3)} = \frac{2}{3}$$

$$m_{BC} = m_2 = \frac{5 + \frac{11}{5}}{3 - \frac{13}{5}} = 18$$

$$\tan \theta = \frac{18 - \frac{2}{3}}{1 + 18 \times \frac{2}{3}} = \frac{4}{3}$$

2. Let  $\vec{a} = \hat{i} + \hat{j} + \hat{k}$  and  $\vec{b} = \hat{j} - \hat{k}$ . If  $\vec{c}$  is a vector such that  $\vec{a} \times \vec{c} = \vec{b}$  and  $\vec{a} \cdot \vec{c} = 3$ , then  $\vec{a} \cdot (\vec{b} \times \vec{c})$  is equal to

- (1) 6 (2) -2  
(3) -6 (4) 2

**Answer (2)**

**Sol.**  $\vec{a} \cdot (\vec{b} \times \vec{c}) = (\vec{b} \times \vec{c}) \cdot \vec{a} = \vec{b} \cdot (\vec{c} \times \vec{a})$

$$= \vec{b} \cdot (-\vec{b}) \quad [\because \vec{a} \times \vec{c} = \vec{b}]$$

$$= -|\vec{b}|^2$$

$$= -(1^2 + (-1)^2) = -2$$

3. Let A and B be independent events such that  $P(A) = p$ ,  $P(B) = 2p$ . The largest value of p for which  $P(\text{exactly one of A, B occurs}) = \frac{5}{9}$ , is

- (1)  $\frac{5}{12}$  (2)  $\frac{2}{9}$   
(3)  $\frac{4}{9}$  (4)  $\frac{1}{3}$

**Answer (1)**

**Sol.**  $P(\text{exactly one of A and B occurs})$

$$= P(A \cap \bar{B}) + P(\bar{A} \cap B)$$

$$= P(A) \times P(\bar{B}) + P(\bar{A})P(B)$$

$$= p \times (1 - 2p) + (1 - p)2p$$

$$3p - 4p^2 = \frac{5}{9}$$

$$27p - 36p^2 = 5$$

$$36p^2 - 27p + 5 = 0$$

$$p = \frac{27 \pm 3}{27} = \frac{5}{12} \text{ and } \frac{1}{3}$$

$$p_{\max} = \frac{5}{12}$$

4. If a line along a chord of the circle  $4x^2 + 4y^2 + 120x + 675 = 0$ , passes through the point  $(-30, 0)$  and is tangent to the parabola  $y^2 = 30x$ , then the length of this chord is

- (1)  $3\sqrt{5}$                       (2)  $5\sqrt{3}$   
 (3) 7                                (4) 5

**Answer (1)**

**Sol.** Circle :  $(x+15)^2 + y^2 = \left(\frac{15}{2}\right)^2$

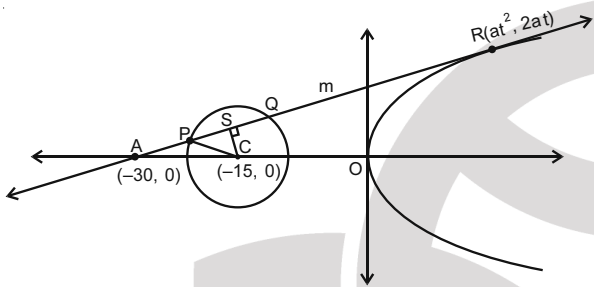

Equation of tangent is

$$ty = x + \frac{15}{2}t^2 \quad \dots(i)$$

(i) passes through  $(-30, 0)$

$$\Rightarrow 0 = -30 + \frac{15}{2}t^2$$

$$\Rightarrow t = \pm 2$$

$$(i) \Rightarrow \pm 2y = x + 30$$

$$\Rightarrow x - 2y + 30 = 0 \text{ or } x + 2y + 30 = 0$$

Consider  $x - 2y + 30 = 0$

$$CS = \left| \frac{-15 - 0 + 30}{\sqrt{5}} \right| = 3\sqrt{5}$$

$$PS = \sqrt{CP^2 - CS^2} = \sqrt{\left(\frac{15}{2}\right)^2 - (3\sqrt{5})^2} = \frac{3\sqrt{5}}{2}$$

$$PQ = 2PS = 3\sqrt{5}$$

5. Let  $y = y(x)$  be a solution curve of the differential equation  $(y + 1) \tan^2 x dx + \tan x dy + y dx = 0$ ,

$x \in \left(0, \frac{\pi}{2}\right)$ . If  $\lim_{x \rightarrow 0^+} xy(x) = 1$ , then the value of

$$y\left(\frac{\pi}{4}\right) \text{ is}$$

- (1)  $\frac{\pi}{4}$                                 (2)  $\frac{\pi}{4} + 1$   
 (3)  $\frac{\pi}{4} - 1$                             (4)  $-\frac{\pi}{4}$

**Answer (1)**

**Sol.**  $(y + 1) \tan^2 x dx + \tan x dy + y dx = 0$

$$(y + 1)(\sec^2 x - 1)dx + \tan x d(y + 1) + y dx = 0$$

$$(y + 1)\sec^2 x dx + \tan x d(y + 1) - (y + 1)dx + y dx = 0$$

$$(y + 1)d(\tan x) + \tan x d(y + 1) = dx$$

$$\int d((y + 1)\tan x) = \int dx$$

$$(y + 1)\tan x = x + C$$

$$y = \frac{x + C}{\tan x} - 1$$

$$\lim_{x \rightarrow 0^+} xy = 1$$

$$\Rightarrow \lim_{x \rightarrow 0} \frac{x}{\tan x} (C + x) - x = 1$$

$$\Rightarrow 1(C + 0) - 0 = 1$$

$$\Rightarrow C = 1$$

$$y = \frac{x + 1}{\tan x} - 1$$

$$y\left(\frac{\pi}{4}\right) = \frac{\pi}{4}$$

6. On the ellipse  $\frac{x^2}{8} + \frac{y^2}{4} = 1$ , let P be a point in the

second quadrant such that the tangent at P to the ellipse is perpendicular to the line  $x + 2y = 0$ . Let S and S' be the foci of the ellipse and e be its eccentricity. If A is the area of the triangle SPS', then the value of  $(5 - e^2) \cdot A$  is

- (1) 12                                (2) 14  
 (3) 6                                 (4) 24

**Answer (3)**

**Sol.** Slope of line =  $-\frac{1}{2}$

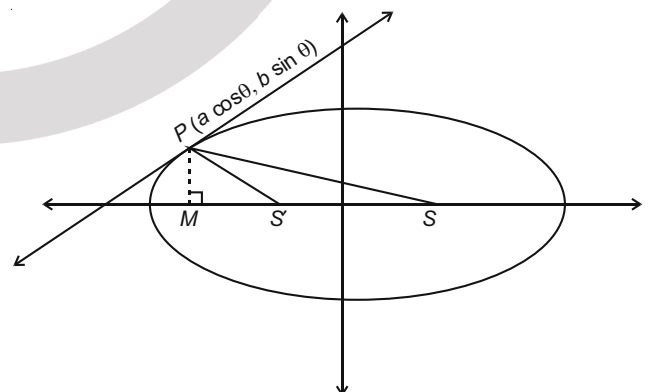

Slope of tangent = 2

Equation of tangent

$$\frac{x}{2\sqrt{2}} \cos \theta + \frac{y}{2} \sin \theta = 1$$

$$\text{Slope} = -\frac{\cos \theta}{\sqrt{2} \sin \theta} = 2$$

$$\tan \theta = \frac{-1}{2\sqrt{2}} \Rightarrow \cos \theta = \frac{-2\sqrt{2}}{3}, \sin \theta = \frac{1}{3}$$

$$P(2\sqrt{2} \cos \theta, 2 \sin \theta) = \left( \frac{-8}{3}, \frac{2}{3} \right)$$

$$PM = \frac{2}{3}$$

$$A = \frac{1}{2} \times SS' \times PM$$

$$= \frac{1}{2} \times 2ae \times \frac{2}{3}$$

$$= \sqrt{a^2 - b^2} \times \frac{2}{3}$$

$$= \sqrt{8-4} \times \frac{2}{3}$$

$$= \frac{4}{3}$$

$$e = \sqrt{1 - \frac{4}{8}} = \frac{1}{\sqrt{2}}$$

$$(5 - e^2) \cdot A = \left( 5 - \left( \frac{1}{\sqrt{2}} \right)^2 \right) \times \frac{4}{3} = 6$$

7. Out of all the patients in a hospital 89% are found to be suffering from heart ailment and 98% are suffering from lungs infection. If K% of them are suffering from both ailments, then K cannot belong to the set:

- (1) {84, 87, 90, 93}  
 (2) {84, 86, 88, 90}  
 (3) {79, 81, 83, 85}  
 (4) {80, 83, 86, 89}

**Answer (3)**

**Sol.** Let A denotes the set of patients suffering from heart ailment and B denotes the set patients suffering from lungs infection.

$$n(A) = 89, n(B) = 98 \text{ and } n(A \cap B) = K$$

$$\therefore n(A \cup B) = n(A) + n(B) - n(A \cap B)$$

$$\Rightarrow 89 + 98 - K \leq 100$$

$$\Rightarrow K \geq 87$$

8. The sum of the series

$$\frac{1}{x+1} + \frac{2}{x^2+1} + \frac{2^2}{x^4+1} + \dots + \frac{2^{100}}{x^{2^{100}}+1} \text{ when } x = 2 \text{ is}$$

(1)  $1 + \frac{2^{101}}{4^{101}-1}$       (2)  $1 - \frac{2^{100}}{4^{100}-1}$

(3)  $1 + \frac{2^{100}}{4^{101}-1}$       (4)  $1 - \frac{2^{101}}{4^{101}-1}$

**Answer (\*)**

**Sol.**  $S = \frac{1}{x+1} + \frac{2}{x^2+1} + \frac{2^2}{x^4+1} + \dots + \frac{2^{100}}{x^{2^{100}}+1}$

$$\Rightarrow S - \frac{1}{x-1} = \left( \frac{-1}{x-1} + \frac{1}{x+1} \right) + \frac{2}{x^2+1} + \frac{2^2}{x^4+1} + \dots + \frac{2^{100}}{x^{2^{100}}+1}$$

$$\Rightarrow S - \frac{1}{x-1} = -\frac{2^{101}}{x^{2^{101}}-1}$$

Put  $x = 2$

$$\Rightarrow S - 1 = -\frac{2^{101}}{2^{2^{101}}-1}$$

$$\Rightarrow S = 1 - \frac{2^{101}}{2^{2^{101}}-1} = 1 - \frac{2^{101}}{4^{2^{100}}-1}$$

9. If  $A = \begin{pmatrix} 1 & 2 \\ \sqrt{5} & \sqrt{5} \\ -2 & 1 \\ \sqrt{5} & \sqrt{5} \end{pmatrix}$ ,  $B = \begin{pmatrix} 1 & 0 \\ i & 1 \end{pmatrix}$ ,  $i = \sqrt{-1}$  and  $Q =$

$A^T B A$ , then the inverse of the matrix  $A Q^{2021} A^T$  is equal to

(1)  $\begin{pmatrix} 1 & 0 \\ 2021i & 1 \end{pmatrix}$       (2)  $\begin{pmatrix} 1 & 0 \\ -2021i & 1 \end{pmatrix}$

(3)  $\begin{pmatrix} 1 & -2021i \\ 0 & 1 \end{pmatrix}$       (4)  $\begin{pmatrix} \frac{1}{\sqrt{5}} & -2021 \\ 2021 & \frac{1}{\sqrt{5}} \end{pmatrix}$

**Answer (2)**

**Sol.**  $\therefore A \cdot A^T = \begin{bmatrix} 1 & 2 \\ \sqrt{5} & \sqrt{5} \\ -2 & 1 \\ \sqrt{5} & \sqrt{5} \end{bmatrix} \begin{bmatrix} 1 & -2 \\ \sqrt{5} & \sqrt{5} \\ \frac{2}{\sqrt{5}} & \frac{1}{\sqrt{5}} \\ \frac{2}{\sqrt{5}} & \frac{1}{\sqrt{5}} \end{bmatrix} = \begin{bmatrix} 1 & 0 \\ 0 & 1 \end{bmatrix} = I$

So,  $A \cdot Q^{2021} \cdot A^T = A(A^T B A)^{2021} \cdot A^T = B^{2021}$

$$\therefore B^2 = \begin{bmatrix} 1 & 0 \\ i & 1 \end{bmatrix} \begin{bmatrix} 1 & 0 \\ i & 1 \end{bmatrix} = \begin{bmatrix} 1 & 0 \\ 2i & 1 \end{bmatrix}$$





**Sol.**  $I = \int_{-\frac{1}{\sqrt{2}}}^{\frac{1}{\sqrt{2}}} \left( \left( \frac{x+1}{x-1} \right)^2 + \left( \frac{x-1}{x+1} \right)^2 - 2 \right)^{\frac{1}{2}} dx$

$$= \int_{-\frac{1}{\sqrt{2}}}^{\frac{1}{\sqrt{2}}} \left( \frac{x+1}{x-1} - \frac{x-1}{x+1} \right)^{\frac{1}{2}} dx$$

$$= \int_{-\frac{1}{\sqrt{2}}}^{\frac{1}{\sqrt{2}}} \left| \frac{4x}{x^2-1} \right| dx = 2 \int_{-\frac{1}{\sqrt{2}}}^{\frac{1}{\sqrt{2}}} \frac{2|x|}{1-x^2} dx$$

$$= 2 \left\{ \int_{-\frac{1}{\sqrt{2}}}^0 \frac{-2x}{1-x^2} dx + \int_0^{\frac{1}{\sqrt{2}}} \frac{2x}{1-x^2} dx \right\}$$

$$= 2 \left\{ \ln(1-x^2) \Big|_{-\frac{1}{\sqrt{2}}}^0 + (-\ln(1-x^2)) \Big|_0^{\frac{1}{\sqrt{2}}} \right\}$$

$$= 2 \left\{ \left( 0 - \ln \frac{1}{2} \right) - \left( \ln \frac{1}{2} - 0 \right) \right\} = 4 \ln 2 = \log_e 16$$

18. The mean and standard deviation of 20 observations were calculated as 10 and 2.5 respectively. It was found that by mistake one data value was taken as 25 instead of 35. If  $\alpha$  and  $\sqrt{\beta}$  are the mean and standard deviation respectively for correct data, then  $(\alpha, \beta)$  is

- (1) (11, 25)                      (2) (11, 26)  
 (3) (10.5, 25)                  (4) (10.5, 26)

**Answer (4)**

**Sol.**  $\bar{x} = 10 \quad \sqrt{\frac{\sum x_i^2}{20} - (\bar{x})^2} = 2.5$

$$\frac{\sum x_i^2}{20} - (10)^2 = 6.25 \Rightarrow \sum x_i^2 = 20 \times 106.25$$

$$= 2125$$

$$\sum x_i^2(\text{actual}) = 2125 - 25^2 + 35^2$$

$$= 2125 + 600 = 2725$$

For  $\bar{x}(\text{actual}) \Rightarrow \frac{\sum x}{n} = 10 \Rightarrow \sum x = 200$

$$\sum X(\text{actual}) = 200 - 25 + 35 = 210$$

$$\bar{x}(\text{actual}) = \frac{210}{20} = 10.5$$

$$\text{S.D.} = \sqrt{\frac{2725}{20} - (10.5)^2} = \sqrt{136.25 - 110.5} = \sqrt{26}$$

19. A plane  $P$  contains the line  $x + 2y + 3z + 1 = 0 = x - y - z - 6$ , and is perpendicular to the plane  $-2x + y + z + 8 = 0$ . Then which of the following points lies on  $P$ ?

- (1) (1, 0, 1)  
 (2) (2, -1, 1)  
 (3) (0, 1, 1)  
 (4) (-1, 1, 2)

**Answer (3)**

**Sol.** Required plane is a plane passing through the line of intersection of planes

$$P_1 \equiv x + 2y + 3z + 1 = 0$$

$$\text{and } P_2 \equiv x - y - z - 6 = 0$$

Its equation:  $P_1 + \lambda P_2 = 0$

$$\Rightarrow (x + 2y + 3z + 1) + \lambda(x - y - z - 6) = 0$$

$$\Rightarrow (1 + \lambda)x + (2 - \lambda)y + (3 - \lambda)z + 1 - 6\lambda = 0$$

$\therefore$  Perpendicular to  $-2x + y + z + 8 = 0$

$$\therefore -2(1 + \lambda) + (2 - \lambda) + (3 - \lambda) = 0$$

$$\Rightarrow \lambda = \frac{3}{4}$$

$$\Rightarrow \text{Required plane is } 7x + 5y + 9z = 14$$

Checking the option shows that (0, 1, 1) satisfies it.

20. Let  $\theta \in \left( 0, \frac{\pi}{2} \right)$ . If the system of linear equations.

$$(1 + \cos^2\theta)x + \sin^2\theta y + 4 \sin 3\theta z = 0$$

$$\cos^2\theta x + (1 + \sin^2\theta)y + 4 \sin 3\theta z = 0$$

$$\cos^2\theta x + \sin^2\theta y + (1 + 4 \sin 3\theta)z = 0$$

has a non-trivial solution, then the value of  $\theta$  is

- (1)  $\frac{7\pi}{18}$                       (2)  $\frac{\pi}{18}$   
 (3)  $\frac{4\pi}{9}$                       (4)  $\frac{5\pi}{18}$

**Answer (1)**

**Sol.**  $\Delta = \begin{vmatrix} 1 + \cos^2\theta & \sin^2\theta & 4 \sin 3\theta \\ \cos^2\theta & 1 + \sin^2\theta & 4 \sin 3\theta \\ \cos^2\theta & \sin^2\theta & 1 + 4 \sin 3\theta \end{vmatrix}$

$$C_1 \rightarrow C_1 + C_2 + C_3$$

$$\Rightarrow \Delta = \begin{vmatrix} 2 + 4 \sin 3\theta & \sin^2\theta & 4 \sin 3\theta \\ 2 + 4 \sin 3\theta & 1 + \sin^2\theta & 4 \sin 3\theta \\ 2 + 4 \sin 3\theta & \sin^2\theta & 1 + 4 \sin 3\theta \end{vmatrix}$$

$$\Rightarrow \Delta = (2 + 4\sin 3\theta) \begin{vmatrix} 1 & \sin^2 \theta & 4\sin 3\theta \\ 1 & 1 + \sin^2 \theta & 4\sin 3\theta \\ 1 & \sin^2 \theta & 1 + 4\sin 3\theta \end{vmatrix}$$

$$R_2 \rightarrow R_2 - R_1 \text{ and } R_3 \rightarrow R_3 - R_1$$

$$\Rightarrow \Delta = \begin{vmatrix} 1 & \sin^2 \theta & 4\sin 3\theta \\ 0 & 1 & 0 \\ 0 & 0 & 1 \end{vmatrix} \times (2 + 4\sin 3\theta)$$

$$\Rightarrow \Delta = (2 + 4\sin 3\theta)$$

For non-trivial solution

$$\Delta = 0$$

$$\Rightarrow \sin 3\theta = \frac{-1}{2}$$

$$\Rightarrow \theta = \frac{7\pi}{18}$$

## SECTION - II

**Numerical Value Type Questions:** This section contains 10 questions. In Section II, attempt any five questions out of 10. The answer to each question is a **NUMERICAL VALUE**. For each question, enter the correct numerical value (in decimal notation, truncated/rounded-off to the second decimal place; e.g. 06.25, 07.00, -00.33, -00.30, 30.27, -27.30) using the mouse and the on-screen virtual numeric keypad in the place designated to enter the answer.

1. Let  $z = \frac{1 - i\sqrt{3}}{2}$ ,  $i = \sqrt{-1}$ . Then the value of

$$21 + \left(z + \frac{1}{z}\right)^3 + \left(z^2 + \frac{1}{z^2}\right)^3 + \left(z^3 + \frac{1}{z^3}\right)^3 + \dots + \left(z^{21} + \frac{1}{z^{21}}\right)^3 \text{ is } \underline{\hspace{2cm}}$$

**Answer (13)**

**Sol.**  $z = \frac{1 - \sqrt{3}i}{2}$

$$z = -\left[\frac{-1 + \sqrt{3}i}{2}\right] = -\omega = z = -\frac{1 + \sqrt{3}i}{2} = -\omega$$

$$21 + \left(-\omega - \frac{1}{\omega}\right)^3 + \left(-\omega^2 + \left(-\frac{1}{\omega}\right)^2\right)^3 + \left(-\omega^3 + \left(-\frac{1}{\omega^3}\right)^3\right)^3 + \dots + \left(-\omega^{21} + \frac{1}{(-\omega)^{21}}\right)^3$$

$$\begin{aligned} &= 21 - (\omega + \omega^2)^3 + (\omega + \omega^2)^3 + (-1 - 1)^3 + (\omega + \omega^2)^3 \\ &\quad - (\omega + \omega^2)^3 + (1 + 1)^3 + \dots + (-\omega - \omega^2)^3 + (\omega^2 + \omega)^3 \\ &\quad + (-\omega^3 - \omega^3)^3 \\ &= 21 + (1 - 1 - 8) + (-1 + 1 + 8) + (1 - 1 - 8) \\ &\quad + (-1 + 1 + 8) + (1 - 1 - 8) + (-1 + 1 + 8) \\ &\quad + (1 - 1 - 8) \\ &= 21 - 8 = 13 \end{aligned}$$

2. The locus of a point, which moves such that the sum of squares of its distances from the points (0, 0), (1, 0), (0, 1), (1, 1) is 18 units, is a circle of diameter  $d$ . Then  $d^2$  is equal to

**Answer (16)**

**Sol.** Let point  $P(h, k)$

$$A(0, 0), B(1, 0), C(0, 1), d(1, 1)$$

$$(PA)^2 + (PB)^2 + (PC)^2 + (PD)^2 = 18$$

$$h^2 + k^2 + (h - 1)^2 + k^2 + h^2 + (k - 1)^2 + (h - 1)^2 + (k - 1)^2 = 18$$

$$4h^2 + 4k^2 - 4h - 4k = 14$$

$$h^2 + k^2 - h - k - \frac{7}{2} = 0$$

$$r = \sqrt{\left(\frac{1}{2}\right)^2 + \left(\frac{1}{2}\right)^2 + \frac{7}{2}}$$

$$r = \sqrt{\frac{1+1+14}{4}} = 2$$

$$d = 4$$

$$d^2 = 16$$

3. If  $y = y(x)$  is an implicit function of  $x$  such that

$$\log_e(x + y) = 4xy, \text{ then } \frac{d^2y}{dx^2} \text{ at } x = 0 \text{ is equal to}$$

**Answer (40)**

**Sol.**  $\log_e(x + y) = 4xy$  at  $x = 0, y = 1$

$$\frac{1}{x+y} \left[1 + \frac{dy}{dx}\right] = 4 \left[y + x \cdot \frac{dy}{dx}\right]$$

$$\frac{1}{x+y} - 4y = \left(4x - \frac{1}{x+y}\right) \frac{dy}{dx}$$

$$1 - 4xy - 4y^2 = (4x^2 + 4xy - 1) \frac{dy}{dx}$$

$$\frac{dy}{dx} = \frac{1 - 4xy - 4y^2}{4x^2 + 4xy - 1}, \text{ at } x = 0, \frac{dy}{dx} = \frac{1 - 4}{-1} = 3$$

$$\frac{d^2y}{dx^2} = \frac{(4x^2 + 4xy - 1) \left[ - \left( 4y + 4x \frac{dy}{dx} \right) - 8y \cdot \frac{dy}{dx} \right] - (1 - 4xy - 4y^2) \left( 8x + 4y + 4x \cdot \frac{dy}{dx} \right)}{(4x^2 + 4xy - 1)^2}$$

at  $x = 0, y = 1, \frac{dy}{dx} = 3$

$$\frac{d^2y}{dx^2} = \frac{(-1)[-4 - 8 \times 3] - (1 - 4)(4)}{1} = 28 + 12 = 40$$

4. The number of three-digit even numbers, formed by the digits 0, 1, 3, 4, 6, 7 if the repetition of digits is not allowed, is \_\_\_\_\_

**Answer (52)**

**Sol.** Three digit even number by 0, 1, 3, 4, 6, 7  
When zero is at unit place

**Case-I**  $\begin{array}{ccc} \downarrow & \downarrow & \downarrow \\ 4 & 5 & 1(0) \end{array} \Rightarrow 4 \times 5 \times 1 = 20$

When zero is not at unit place

**Case-II**  $\begin{array}{ccc} \downarrow & \downarrow & \downarrow \\ 4 & 4 & 2(4, 6) \end{array} = 4 \times 4 \times 2 = 32$

Total three digit even number =  $20 + 32 = 52$

5. The sum of all integral values of  $k(k \neq 0)$  for which the equation  $\frac{2}{x-1} - \frac{1}{x-2} = \frac{2}{k}$  in  $x$  has no real roots, is \_\_\_\_\_.

**Answer (66)**

**Sol.**  $\frac{2}{x-1} - \frac{1}{x-2} = \frac{2}{k}$

$$\Rightarrow \frac{2x - 4 - x + 1}{(x-1)(x-2)} = \frac{2}{k}$$

$$\Rightarrow 2x^2 - 6x + 4 = k(x - 3)$$

$$\Rightarrow 2x^2 - x(6 + k) + (4 + 3k) = 0$$

This equation has no solution then

$$(6 + k)^2 < 4 \cdot 2(4 + 3k)$$

$$\Rightarrow k^2 - 12k + 4 < 0$$

$$\Rightarrow k \in (6 - 4\sqrt{2}, 6 + 4\sqrt{2})$$

$$\Rightarrow k = 1, 2, 3, \dots, 11$$

Sum of all values of  $k$

$$11 \left( \frac{11+1}{2} \right) = 66$$

6. The area of the region  $S = \{(x, y) : 3x^2 \leq 4y \leq 6x + 24\}$  is \_\_\_\_\_.

**Answer (27)**

**Sol.**

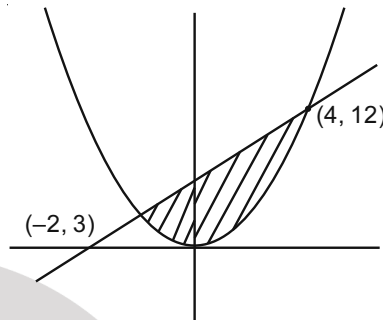

$$\frac{3x^2}{4} \leq y \leq \frac{3x}{2} + 6$$

Point of intersection for two curves

$$y = \frac{3x^2}{4} \text{ \& } y = \frac{3x}{2} + 6 \text{ are } (-2, 3) \text{ \& } (4, 12)$$

Area of shaded region

$$\int_{-2}^4 \left( \frac{3x}{2} + 6 - \frac{3x^2}{4} \right) dx = \frac{3x^2}{4} + 6x - \frac{x^3}{4} \Big|_{-2}^4 = 20 - (-7) = 27$$

7. If  $1 \cdot {}^1P_1 + 2 \cdot {}^2P_2 + 3 \cdot {}^3P_3 + \dots + 15 \cdot {}^{15}P_{15} = {}^qP_r - s$ ,  $0 \leq s \leq 1$ , then  ${}^{q+s}C_{r-s}$  is equal to \_\_\_\_\_.

**Answer (136)**

**Sol.**  $\sum_{r=1}^{15} r \cdot {}^rP_r = \sum_{r=1}^{15} r \cdot r! = \sum_{r=1}^{15} (r+1-1) \cdot r!$

$$= \sum_{r=1}^{15} (r+1)r! - r! = \sum_{r=1}^{15} (r+1)! - r!$$

$$T_1 = 2! - 1!$$

$$T_2 = 3! - 2!$$

$$T_3 = 4! - 3!$$

⋮

$$T_{15} = 16! - 15!$$

$$\text{Sum} = 16! - 1 = {}^{16}P_{16} - 1$$

$$q = 16, r = 16, s = 1$$

$${}^{q+s}C_{r-s} = {}^{17}C_{15}$$

$$= 136$$

8. A wire of length 36 m is cut into two pieces, one of the pieces is bent to form a square and the other is bent to form a circle. If the sum of the areas of the two figures is minimum, and the circumference of the circle is  $k$  (meter), then  $\left(\frac{4}{\pi} + 1\right)k$  is equal to \_\_\_\_\_.

**Answer (36)**

**Sol.** Let  $x$  m is used to form circle and  $(36 - x)$  m is used to form square. If radius of circle is  $r$

$$2\pi r = x \Rightarrow r = \frac{x}{2\pi}$$

$$\text{Side of Square} = \frac{36 - x}{4}$$

$$\text{Sum of Area} = \pi \left(\frac{x}{2\pi}\right)^2 + \left(\frac{36 - x}{4}\right)^2 = A$$

$$\frac{dA}{dx} = \frac{2x}{4\pi} - \frac{2}{4} \left(\frac{36 - x}{4}\right)$$

$$\text{To minimize } \frac{dA}{dx} = 0 \Rightarrow x = \frac{36\pi}{4 + \pi} = k$$

$$\left(\frac{4}{\pi} + 1\right) \cdot \frac{36\pi}{4 + \pi} = \frac{4 + \pi}{\pi} \cdot \frac{36\pi}{4 + \pi} = 36$$

9. Let  $a, b, \in \mathbf{R}$ ,  $b \neq 0$ . Define a function

$$f(x) = \begin{cases} a \sin \frac{\pi}{2}(x - 1), & \text{for } x \leq 0 \\ \frac{\tan 2x - \sin 2x}{bx^3}, & \text{for } x > 0. \end{cases}$$

If  $f$  is continuous at  $x = 0$ , then  $10 - ab$  is equal to \_\_\_\_\_.

**Answer (14)**

**Sol.** L.H.L. at  $x = 0$  for  $f(x)$

$$\lim_{x \rightarrow 0^-} a \sin \frac{\pi}{2}(x - 1) = a \sin \left(-\frac{\pi}{2}\right) = -a$$

R.H.L. at  $x = 0$  for  $f(x)$

$$\begin{aligned} \lim_{x \rightarrow 0^+} \frac{\tan 2x - \sin 2x}{bx^3} &= \lim_{x \rightarrow 0^+} \frac{\tan 2x (1 - \cos 2x)}{x \cdot x^2} \cdot \frac{1}{b} \\ &= \frac{1}{b} \lim_{x \rightarrow 0^+} \frac{\tan 2x}{x} \cdot \frac{1 - \cos 2x}{4x^2} \cdot 4 \\ &= \frac{1}{b} \cdot 2 \cdot \frac{1}{2} \cdot 4 = \frac{4}{b} \end{aligned}$$

$$\text{For continuity } -a = \frac{4}{b} \Rightarrow ab = -4$$

$$\text{So, } 10 - ab = 14$$

10. Let the line  $L$  be the projection of the line

$$\frac{x - 1}{2} = \frac{y - 3}{1} = \frac{z - 4}{2}$$

in the plane  $x - 2y - z = 3$ . If  $d$  is the distance of the point  $(0, 0, 6)$  from  $L$ , then  $d^2$  is equal to \_\_\_\_\_.

**Answer (26)**

$$\text{Sol. } L : \frac{x - 1}{2} = \frac{y - 3}{1} = \frac{z - 4}{2}$$

$$P_1 : x - 2y - z = 3$$

Equation of a plane  $P_2$  which contains  $L$  and perpendicular to  $P_1$ ,

$$\begin{vmatrix} x - 1 & y - 3 & z - 4 \\ 1 & -2 & -1 \\ 2 & 1 & 2 \end{vmatrix} = 0$$

$$\Rightarrow 3x + 4y - 5z + 5 = 0$$

Distances of point  $(0, 0, 6)$  from  $P_1$  and  $P_2$  are

$$d_1 = \frac{25}{\sqrt{50}} = \sqrt{\frac{25}{2}} \quad \text{and} \quad d_2 = \frac{9}{\sqrt{6}} = \sqrt{\frac{27}{2}}$$

$$\text{Now } d^2 = d_1^2 + d_2^2 = 26$$

