



[www.uniqueworldedu.com](http://www.uniqueworldedu.com)

Dubai and Abu Dhabi

Contact us on Tel: +971 4 357 4415 Tel: +971 2 627 8480

■ India's First Medical and Engineering Entrance Coaching centre by Prof. **P.C THOMAS** now in UAE ■

Time : 3 hrs.

## Answers & Solutions

M.M. : 300

*for*

## JEE (MAIN)-2021 (Online) Phase-3

(Physics, Chemistry and Mathematics)

### IMPORTANT INSTRUCTIONS :

- (1) The test is of **3 hours** duration.
- (2) The Test Booklet consists of 90 questions. The maximum marks are 300.
- (3) There are **three** parts in the question paper A, B, C consisting of **Physics, Chemistry** and **Mathematics** having 30 questions in each part of equal weightage. Each part has two sections.
  - (i) Section-I : This section contains 20 multiple choice questions which have only one correct answer. Each question carries **4 marks** for correct answer and **-1 mark** for wrong answer.
  - (ii) Section-II : This section contains 10 questions. In Section-II, attempt any **five questions out of 10**. There will be **no negative marking for Section-II**. The answer to each of the questions is a numerical value. Each question carries **4 marks** for correct answer and there is no negative marking for wrong answer.

## PART-A : PHYSICS

### SECTION - I

**Multiple Choice Questions:** This section contains 20 multiple choice questions. Each question has 4 choices (1), (2), (3) and (4), out of which **ONLY ONE** is correct.

**Choose the correct answer :**

1. The force is given in terms of time  $t$  and displacement  $x$  by the equation

$$F = A \cos Bx + C \sin Dt$$

The dimensional formula of  $\frac{AD}{B}$  is

- (1)  $[M^1 L^1 T^{-2}]$                       (2)  $[M^0 L T^{-1}]$   
 (3)  $[M^2 L^2 T^{-3}]$                       (4)  $[M L^2 T^{-3}]$

**Answer (4)**

**Sol.**  $F = A \cos Bx + C \sin Dt$

$$\therefore \left[ \frac{AD}{B} \right] = \frac{MLT^{-2} \times T^{-1}}{L^{-1}}$$

$$= [ML^2 T^{-3}]$$

2. Two spherical soap bubbles of radii  $r_1$  and  $r_2$  in vacuum combine under isothermal conditions. The resulting bubble has a radius equal to

- (1)  $\frac{r_1 + r_2}{2}$                                   (2)  $\sqrt{r_1 r_2}$   
 (3)  $\frac{r_1 r_2}{r_1 + r_2}$                               (4)  $\sqrt{r_1^2 + r_2^2}$

**Answer (4)**

**Sol.**  $p_0 = 0$

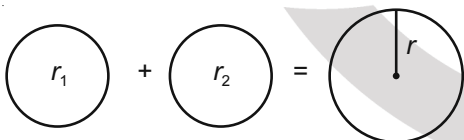

$$P_1 = P_0 + \frac{4T}{r_1}, P_2 = P_0 + \frac{4T}{r_2}, P = P_0 + \frac{4T}{r}$$

$$\text{and } n_1 + n_2 = n$$

$$\Rightarrow \frac{P_1 V_1}{RT} + \frac{P_2 V_2}{RT} = \frac{P \times V}{RT}$$

$$\Rightarrow r_1^2 + r_2^2 = r^2$$

$$\Rightarrow r = \sqrt{r_1^2 + r_2^2}$$

3. A prism of refractive index  $\mu$  and angle of prism  $A$  is placed in the position of minimum angle of deviation. If minimum angle of deviation is also  $A$ , then in terms of refractive index value of  $A$  is

- (1)  $2 \cos^{-1} \left( \frac{\mu}{2} \right)$   
 (2)  $\cos^{-1} \left( \frac{\mu}{2} \right)$   
 (3)  $\sin^{-1} \left( \frac{\mu}{2} \right)$   
 (4)  $\sin^{-1} \left( \sqrt{\frac{\mu-1}{2}} \right)$

**Answer (1)**

**Sol.**  $\delta_m = A$

$$\therefore \mu = \frac{\sin \left( \frac{A + \delta_m}{2} \right)}{\sin \left( \frac{A}{2} \right)}$$

$$\Rightarrow \mu = \frac{\sin A}{\sin \left( \frac{A}{2} \right)} = 2 \cos \left( \frac{A}{2} \right)$$

$$\Rightarrow \frac{A}{2} = \cos^{-1} \left( \frac{\mu}{2} \right)$$

$$\Rightarrow A = 2 \cos^{-1} \left( \frac{\mu}{2} \right)$$

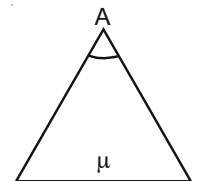

4. The relation between time  $t$  and distance  $x$  for a moving body is given as  $t = mx^2 + nx$ , where  $m$  and  $n$  are constants. The retardation of the motion is:

(Where  $v$  stands for velocity)

- (1)  $2nv^3$                                       (2)  $2mv^3$   
 (3)  $2mnv^3$                                   (4)  $2n^2v^3$

**Answer (2)**

**Sol.**  $t = mx^2 + nx$

$$\Rightarrow 1 = m \times 2x v + n \times v$$

$$\Rightarrow v = \frac{1}{2mx + n}$$

$$\therefore \frac{dv}{dt} = \frac{1}{(2mx + n)^2} \times (2m)^2 \times v$$

$$\Rightarrow a = (2m) \times v \times v^2$$

$$= 2mv^3$$

5. In the given potentiometer circuit arrangement, the balancing length AC is measured to be 250 cm. When the galvanometer connection is shifted from point (1) to point (2) in the given diagram, the balancing length becomes 400 cm. The ratio of the emf of two cells,  $\frac{\epsilon_1}{\epsilon_2}$  is

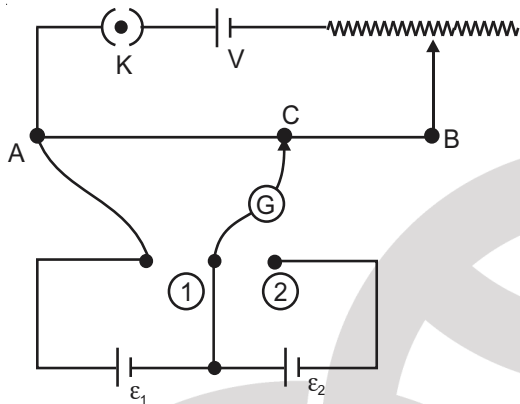

- (1)  $\frac{3}{2}$  (2)  $\frac{5}{3}$   
 (3)  $\frac{8}{5}$  (4)  $\frac{4}{3}$

**Answer (2)**

**Sol.**  $\epsilon_1 \propto 250$

$$\epsilon_1 + \epsilon_2 \propto 400$$

$$\Rightarrow \frac{\epsilon_1 + \epsilon_2}{\epsilon_1} = \frac{400}{250} = \frac{8}{5}$$

$$\Rightarrow 1 + \frac{\epsilon_2}{\epsilon_1} = \frac{8}{5}$$

$$\Rightarrow \frac{\epsilon_2}{\epsilon_1} = \frac{3}{5} \Rightarrow \frac{\epsilon_1}{\epsilon_2} = \frac{5}{3}$$

6. When radiation of wavelength  $\lambda$  is incident on a metallic surface, the stopping potential of ejected photoelectrons is 4.8 V. If the same surface is illuminated by radiation of double the previous wavelength, then the stopping potential becomes 1.6 V. The threshold wavelength of the metal is

- (1)  $6\lambda$  (2)  $4\lambda$   
 (3)  $8\lambda$  (4)  $2\lambda$

**Answer (2)**

**Sol.**  $\frac{hc}{\lambda} = \frac{hc}{\lambda_0} + 4.8$  ... (i)

$$\frac{hc}{2\lambda} = \frac{hc}{\lambda_0} + 1.6$$
 ... (ii)

Eq. (i)  $\div$  eq. (ii),

$$\Rightarrow 2 = \frac{\frac{hc}{\lambda_0} + 4.8}{\frac{hc}{\lambda_0} + 1.6}$$

$$\Rightarrow \frac{hc}{\lambda_0} = 1.6 \Rightarrow \lambda_0 = 4\lambda$$

7. The given potentiometer has its wire of resistance  $10\ \Omega$ . When the sliding contact is in the middle of the potentiometer wire, the potential drop across  $2\ \Omega$  resistor is

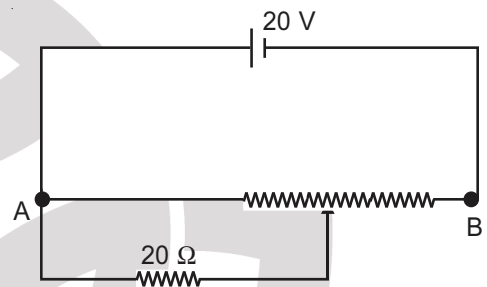

- (1) 5 V (2) 10 V  
 (3)  $\frac{40}{9}$  V (4)  $\frac{40}{11}$  V

**Answer (3)**

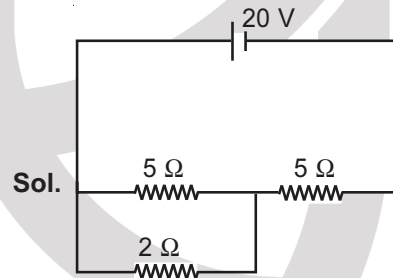

$$R_1 = \frac{10}{7}, R_2 = 5$$

$$\Rightarrow \frac{R_1}{R_2} = \frac{2}{7}$$

$$V_{2\Omega} = \frac{2}{9} \times 20 = \frac{40}{9} \text{ V}$$

8. A force  $\vec{F} = (40\hat{i} + 10\hat{j})$  N acts on a body of mass 5 kg. If the body start from rest, its position vector  $\vec{r}$  at time  $t = 10$  s, will be

- (1)  $(400\hat{i} + 400\hat{j})$  m (2)  $(400\hat{i} + 100\hat{j})$  m  
 (3)  $(100\hat{i} + 400\hat{j})$  m (4)  $(100\hat{i} + 100\hat{j})$  m

**Answer (2)**

**Sol.**  $\vec{r} = \vec{u}t + \frac{1}{2}\vec{a}t^2$

$$= \frac{1}{2} \times (8\hat{i} + 2\hat{j}) \times 100$$

$$= (400\hat{i} + 100\hat{j}) \text{ m}$$

9. A balloon was moving upwards with a uniform velocity of 10 m/s. An object of finite mass is dropped from the balloon when it was at a height of 75 m from the ground level. The height of the balloon from the ground when object strikes the ground was around

- (takes the value of  $g$  as  $10 \text{ m/s}^2$ )
- (1) 250 m                      (2) 125 m  
 (3) 300 m                      (4) 200 m

**Answer (2)**

**Sol.**  $-75 = 10t - \frac{1}{2} \times (10)t^2$

$$\Rightarrow -15 = 2t - t^2$$

$$\Rightarrow t^2 - 2t - 15 = 0$$

$$\Rightarrow t = 5 \text{ s}$$

$$H = 75 + 10 \times 5$$

$$= 125 \text{ m}$$

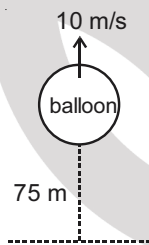

10. A ray of light entering from air into a denser medium of refractive index  $\frac{4}{3}$ , as shown in figure.

The light ray suffers total internal reflection at the adjacent surface as shown. The maximum value of angle  $\theta$  should be equal to

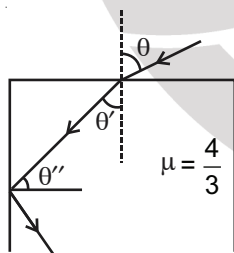

- (1)  $\sin^{-1} \frac{\sqrt{5}}{4}$                       (2)  $\sin^{-1} \frac{\sqrt{7}}{3}$   
 (3)  $\sin^{-1} \frac{\sqrt{5}}{3}$                       (4)  $\sin^{-1} \frac{\sqrt{7}}{4}$

**Answer (2)**

**Sol.**  $\frac{4}{3} \sin \theta'' = 1 \Rightarrow \sin \theta'' = \frac{3}{4}$

$$\frac{4}{3} \sin \theta' = 1 \times \sin \theta$$

$$\Rightarrow \sin \theta = \frac{4}{3} \sqrt{1 - \frac{9}{16}}$$

$$= \frac{4}{3} \sqrt{\frac{7}{16}} = \frac{\sqrt{7}}{3}$$

11. Two ions having same mass have charges in the ratio 1 : 2. They are projected normally in a uniform magnetic field with their speeds in the ratio 2 : 3. The ratio of the radii of their circular trajectories is

- (1) 2 : 3                      (2) 3 : 1  
 (3) 1 : 4                      (4) 4 : 3

**Answer (4)**

**Sol.**  $R = \frac{mv}{qB}$

$$\frac{q_1}{q_2} = \frac{1}{2}, \frac{v_1}{v_2} = \frac{2}{3}$$

$$\frac{R_1}{R_2} = \frac{v_1}{q_1} \times \frac{q_2}{v_2} = \frac{v_1}{v_2} \times \frac{q_2}{q_1}$$

$$= \frac{2}{3} \times 2 = \frac{4}{3}$$

12. If  $q_f$  is the free charge on the capacitor plates and  $q_b$  is the bound charge on the dielectric slab of dielectric constant  $k$  placed between the capacitor plates, then bound charge  $q_b$  can be expressed as

- (1)  $q_b = q_f \left(1 + \frac{1}{\sqrt{k}}\right)$                       (2)  $q_b = q_f \left(1 - \frac{1}{\sqrt{k}}\right)$   
 (3)  $q_b = q_f \left(1 + \frac{1}{k}\right)$                       (4)  $q_b = q_f \left(1 - \frac{1}{k}\right)$

**Answer (4)**

**Sol.** We know

$$q_b = q_f \left(1 - \frac{1}{k}\right)$$

13. A heat engine has an efficiency of  $\frac{1}{6}$ . When the temperature of sink is reduced by  $62^\circ\text{C}$ , its efficiency get doubled. The temperature of the source is

- (1)  $37^\circ\text{C}$                       (2)  $99^\circ\text{C}$   
 (3)  $124^\circ\text{C}$                       (4)  $62^\circ\text{C}$

**Answer (2)**

**Sol.**  $\eta = 1 - \frac{T_L}{T_H}$

$$\Rightarrow \frac{1}{6} = 1 - \frac{T_L}{T_H} \Rightarrow \frac{T_L}{T_H} = \frac{5}{6} \quad \dots(i)$$

Now,  $2 \times \frac{1}{6} = 1 - \frac{T_L - 62}{T_H} \Rightarrow \frac{T_L - 62}{T_H} = \frac{2}{3} \quad \dots(ii)$

from (i) and (ii)

$$\frac{T_L}{T_L - 62} = \frac{5}{6} \times \frac{3}{2} = \frac{5}{4}$$

$$4T_L = 5T_L - 310$$

$$T_L = 310 \text{ K}$$

from (i)

$$\begin{aligned} T_H &= \frac{6}{5} \times T_L = \frac{6}{5} \times 310 = 372 \text{ K} \\ &= (372 - 273)^\circ\text{C} \\ &= 99^\circ\text{C} \end{aligned}$$

14. The instantaneous velocity of a particle moving in a straight line is given as  $v = \alpha t + \beta t^2$ , where  $\alpha$  and  $\beta$  are constants. The distance travelled by the particle between 1 s and 2 s is

(1)  $\frac{3}{2}\alpha + \frac{7}{3}\beta$                       (2)  $\frac{\alpha}{2} + \frac{\beta}{3}$

(3)  $\frac{3}{2}\alpha + \frac{7}{2}\beta$                       (4)  $3\alpha + 7\beta$

**Answer (1)**

**Sol.**  $v = \alpha t + \beta t^2$

$$\int dx = \int_1^2 (\alpha t + \beta t^2) dt$$

$$= \alpha \left[ \frac{t^2}{2} \right]_1^2 + \beta \left[ \frac{t^3}{3} \right]_1^2$$

$$= \frac{3}{2}\alpha + \frac{7}{3}\beta$$

15. A  $10 \Omega$  resistance is connected across 220 V - 50 Hz AC supply. The time taken by the current to change from its maximum value to the rms value is

- (1) 2.5 ms                      (2) 4.5 ms  
(3) 1.5 ms                      (4) 3.0 ms

**Answer (1)**

**Sol.**  $i = \frac{220}{R} \sin \omega t$ ,  $T = \frac{1}{50}$  s

time required for maximum to rms

$$\begin{aligned} &= \frac{T}{8} \\ &= \frac{1}{50 \times 8} \text{ s} \\ &= \frac{1}{400} \text{ s} \\ &= 2.5 \text{ ms} \end{aligned}$$

16. An electron moving with speed  $v$  and a photon moving with speed  $c$ , have same de-Broglie wavelength. The ratio of kinetic energy of electron to that of photon is

- (1)  $\frac{v}{3c}$                                       (2)  $\frac{v}{2c}$   
(3)  $\frac{3c}{v}$                                       (4)  $\frac{2c}{v}$

**Answer (2)**

**Sol.**  $\frac{h}{mv} = \lambda$

$$k_e = \frac{h^2}{2m\lambda^2}$$

$$k_{ph} = \frac{hc}{\lambda} = \frac{hc}{\lambda}$$

$$\frac{k_e}{k_{ph}} = \frac{h^2}{2m\lambda^2} \times \frac{\lambda}{hc}$$

$$\begin{aligned} \text{ratio} &= \frac{h}{2m\lambda c} = \frac{h}{2mc \times \frac{h}{mv}} \\ &= \frac{v}{2c} \end{aligned}$$

17. In a simple harmonic oscillation, what fraction of total mechanical energy is in the form of kinetic energy, when the particle is midway between mean and extreme position?

- (1)  $\frac{3}{4}$                                       (2)  $\frac{1}{4}$   
(3)  $\frac{1}{3}$                                       (4)  $\frac{1}{2}$

**Answer (1)**

Sol.  $U = \frac{1}{2} m \omega^2 A^2$

$$v = \omega \sqrt{A^2 - \frac{A^2}{4}}$$

$$k = \frac{1}{2} m v^2 = \frac{1}{2} m \omega^2 \times \frac{3A^2}{4}$$

18. Two vectors  $\vec{X}$  and  $\vec{Y}$  have equal magnitude. The magnitude of  $(\vec{X} - \vec{Y})$  is  $n$  times the magnitude of  $(\vec{X} + \vec{Y})$ . The angle between  $\vec{X}$  and  $\vec{Y}$  is :

(1)  $\cos^{-1}\left(\frac{n^2+1}{n^2-1}\right)$       (2)  $\cos^{-1}\left(\frac{n^2+1}{-n^2-1}\right)$

(3)  $\cos^{-1}\left(\frac{-n^2-1}{n^2-1}\right)$       (4)  $\cos^{-1}\left(\frac{n^2-1}{-n^2-1}\right)$

Answer (4)

Sol.  $|\vec{X} + \vec{Y}|^2 = X^2 + Y^2 + 2XY \cos \theta$

$$|\vec{X} - \vec{Y}|^2 = X^2 + Y^2 - 2XY \cos \theta$$

$$n^2 = \frac{2 - 2 \cos \theta}{2 + 2 \cos \theta}$$

$$n^2 = \frac{1 - \cos \theta}{1 + \cos \theta}$$

$$n^2 + n^2 \cos \theta = 1 - \cos \theta$$

$$\cos \theta = -\left(\frac{n^2 - 1}{n^2 + 1}\right)$$

19. Two ideal electric dipoles A and B, having their dipole moment  $p_1$  and  $p_2$  respectively are placed on a plane with their centres at O as shown in the figure. At point C on the axis of dipole A, the resultant electric field is making an angle of  $37^\circ$  with the axis.

The ratio of the dipole moment of A and B,  $\frac{p_1}{p_2}$  is:

(take  $\sin 37^\circ = \frac{3}{5}$ )

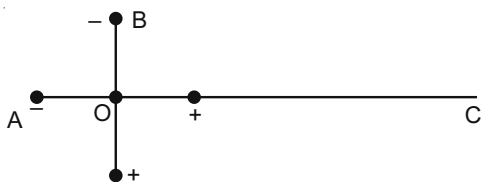

(1)  $\frac{2}{3}$

(2)  $\frac{4}{3}$

(3)  $\frac{3}{2}$

(4)  $\frac{3}{8}$

Answer (1)

Sol.  $\vec{E}_C = \vec{E}_1 + \vec{E}_2$

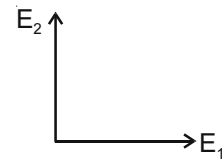

$$E_1 = \frac{2p_1}{4\pi\epsilon_0 r^3} \hat{i}$$

$$E_2 = \frac{p_2}{4\pi\epsilon_0 r^3} \hat{j}$$

$$\tan 37^\circ = \frac{E_2}{E_1} = \frac{p_2}{2p_1}$$

$$\frac{3}{4} = \frac{p_2}{2p_1}$$

$$\frac{p_1}{p_2} = \frac{2}{3}$$

20. Consider a planet in some solar system which has a mass double the mass of earth and density equal to the average density of earth. If the weight of an object on earth is  $W$ , the weight of the same object on that planet will be:

(1)  $2W$

(2)  $2^{1/3}W$

(3)  $\sqrt{2}W$

(4)  $W$

Answer (2)

Sol.  $g_{\text{eff}} = \frac{GM}{R^2}$

$$2 \times \rho \times \frac{4}{3} \pi R_1^3 = \frac{4}{3} \pi R_2^3 \times \rho$$

$$R_2 = 2^{1/3} R$$

$$g_1 = \frac{GM}{R^2}$$

$$g_2 = \frac{2GM}{[2^{1/3}R]^2} = \frac{2^{1/3}GM}{R^2}$$

### SECTION - II

**Numerical Value Type Questions:** This section contains 10 questions. In Section II, attempt any five questions out of 10. The answer to each question is a **NUMERICAL VALUE**. For each question, enter the correct numerical value (in decimal notation, truncated/rounded-off to the second decimal place; e.g. 06.25, 07.00, -00.33, -00.30, 30.27, -27.30) using the mouse and the on-screen virtual numeric keypad in the place designated to enter the answer.

1. In a semiconductor, the number density of intrinsic charge carriers at  $27^\circ\text{C}$  is  $1.5 \times 10^{16}/\text{m}^3$ . If the semiconductor is doped with impurity atom, the hole density increases to  $4.5 \times 10^{22}/\text{m}^3$ . The electron density in the doped semiconductor is \_\_\_\_\_  $\times 10^9/\text{m}^3$ .

**Answer (5)**

**Sol.**  $n_e n_h = n_i^2$

$$n_e = \frac{(1.5 \times 10^{16})^2}{4.5 \times 10^{22}} = 5 \times 10^9/\text{m}^3$$

2. A  $16 \Omega$  wire is bent to form a square loop. A  $9 \text{ V}$  supply having internal resistance of  $1 \Omega$  is connected across one of its sides. The potential drop across the diagonals of the square loop is \_\_\_\_\_  $\times 10^{-1} \text{ V}$ .

**Answer (45)**

**Sol.**

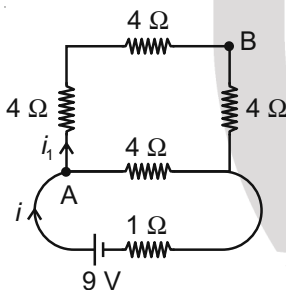

$$i = \frac{9}{\frac{4 \times 12}{4 + 12} + 1} = \frac{9}{4} \text{ A}$$

$$i_1 = \frac{9}{16} \text{ A}$$

$$V_A - V_B = i_1 \times R$$

$$= \frac{9}{16} \cdot 8 = \frac{9}{2} \text{ V}$$

$$= 4.5 \text{ V}$$

3. A force of  $F = (5y + 20)\hat{j} \text{ N}$  acts on a particle. The workdone by this force when the particle is moved from  $y = 0 \text{ m}$  to  $y = 10 \text{ m}$  is \_\_\_\_\_ J.

**Answer (450)**

**Sol.**  $W = \int \vec{F} \cdot d\vec{r}$

$$= \int_0^{10} (5y + 20) dy$$

$$= 450 \text{ J}$$

4. The nuclear activity of a radioactive element becomes  $\left(\frac{1}{8}\right)^{\text{th}}$  of its initial value in 30 years. The half-life of radioactive element is \_\_\_\_\_ years.

**Answer (10)**

**Sol.**  $A = \frac{A_0}{2^n}$

$$\Rightarrow n = 3$$

$$\Rightarrow T_{1/2} = 10 \text{ years}$$

5. Two circuits are shown in the figure (a) and (b). At a frequency of \_\_\_\_\_ rad/s the average power dissipated in one cycle will be same in both the circuits.

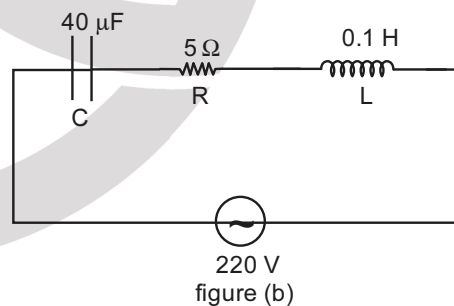
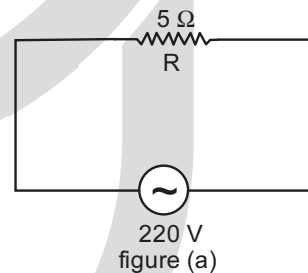

**Answer (500)**

**Sol.**  $\frac{V^2}{R} = \frac{V^2}{Z^2} R$

$$\Rightarrow Z = R$$

$$\Rightarrow \omega = \frac{1}{\sqrt{LC}} = 500 \text{ rad/s}$$

6. A light beam of wavelength 500 nm is incident on a metal having work function of 1.25 eV, placed in a magnetic field of intensity B. The electrons emitted perpendicular to the magnetic field B, with maximum kinetic energy are bent into circular arc of radius 30 cm. The value of B is  $\underline{\hspace{1cm}} \times 10^{-7}$  T.

Given  $hc = 20 \times 10^{-26}$  J-m, mass of electron =  $9 \times 10^{-31}$  kg

**Answer (125)**

**Sol.**  $R = \frac{\sqrt{2mKE}}{qB}$  where  $KE = \frac{hc}{\lambda} - 2 \times 10^{-19}$

$$= \frac{\sqrt{2 \times 9 \times 10^{-31} \times 2 \times 10^{-19}}}{1.6 \times 10^{-19} \times B}$$

$$B = \frac{6 \times 10^{-25}}{0.3 \times 1.6 \times 10^{-19}} = 125 \times 10^{-7} \text{ T}$$

7. From the given data, the amount of energy required to break the nucleus of aluminium  ${}_{13}^{27}\text{Al}$  is  $\underline{\hspace{1cm}} \times 10^{-3}$  J.

Mass of neutron = 1.00866 u

Mass of proton = 1.00726 u

Mass of Aluminium nucleus = 27.18846 u

(Assume 1 u corresponds to x J of energy)

(Round off to the nearest integer)

**Answer (27)**

**Sol.** B.E. =  $[13(1.00726) + 14(1.00866) - 27.18846]x$  J

$$[13.09438 + 14.12124 - 27.18846] x J$$

$$= (0.02716) x J$$

$$= 27.16 \times 10^{-3} x J$$

$$= 27$$

8. A system consists of two types of gas molecules A and B having same number density  $2 \times 10^{25}/\text{m}^3$ . The diameter of A and B are 10 Å and 5 Å respectively. They suffer collision at room temperature. The ratio of average distance covered by the molecule A to that of B between two successive collision is  $\underline{\hspace{1cm}} \times 10^{-2}$

**Answer (25)**

**Sol.**  $\lambda \propto \frac{1}{d^2}$

$$\frac{\lambda_{10}}{\lambda_5} = \frac{1}{4} = 0.25$$

9. A solid disc of radius 20 cm and mass 10 kg is rotating with an angular velocity of 600 rpm, about an axis normal to its circular plane and passing through its centre of mass. The retarding torque required to bring the disc at rest in 10 s is  $\underline{\hspace{1cm}} \pi \times 10^{-1}$  Nm.

**Answer (4)**

**Sol.**  $\Delta L = \tau \Delta t$

$$\tau = \frac{\frac{1}{2} m R^2 \omega}{10} = \frac{\frac{1}{2} \times 10 \times 0.04 \times 600 \times 2\pi}{10 \times 60}$$

$$= \frac{24\pi}{60}$$

$$= 0.4\pi$$

$$= 4 \times \pi \times 10^{-1}$$

10. A message signal of frequency 20 kHz and peak voltage of 20 volt is used to modulate a carrier wave of frequency 1 MHz and peak voltage of 20 volt. The modulation index will be  $\underline{\hspace{1cm}}$ .

**Answer (1)**

**Sol.**  $m = \frac{M}{A} = \frac{\text{modulation amplitude}}{\text{Carrier amplitude}}$

$$= \frac{20}{20} = 1$$



## PART-B : CHEMISTRY

### SECTION - I

**Multiple Choice Questions:** This section contains 20 multiple choice questions. Each question has 4 choices (1), (2), (3) and (4), out of which **ONLY ONE** is correct.

**Choose the correct answer :**

1. Given below are two statements :

**Statement I :** Chlorofluoro carbons breakdown by radiation in the visible energy region and release chlorine gas in the atmosphere which then reacts with stratospheric ozone.

**Statement II :** Atmospheric ozone reacts with nitric oxide to give nitrogen and oxygen gases, which add to the atmosphere.

For the above statements choose the correct answer from the options given below :

- (1) Statement I is incorrect but statement II is true
- (2) Statement I is correct but statement II is false
- (3) Both statement I and II are correct
- (4) Both statement I and II are false

**Answer (4)**

**Sol.** Chlorofluoro carbons breakdown by radiation in the UV region and not in the visible region to give chlorine free radical which reacts with stratospheric ozone.



Atmospheric ozone reacts with NO to give NO<sub>2</sub> and O<sub>2</sub> and not N<sub>2</sub> and O<sub>2</sub>

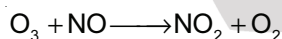

Both the given statements are false.

2. The correct decreasing order of densities of the following compounds is :

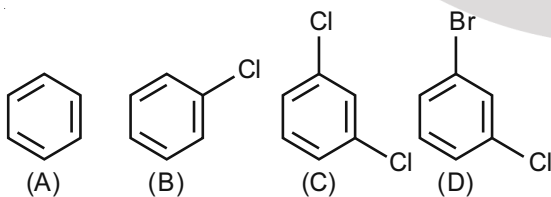

- (1) (D) > (C) > (B) > (A)
- (2) (C) > (B) > (A) > (D)
- (3) (A) > (B) > (C) > (D)
- (4) (C) > (D) > (A) > (B)

**Answer (1)**

**Sol.** The density of the given organic compounds is decided by their molecular mass and polarity. Higher the molecular mass and higher the polarity, higher will be the density.

∴ Correct order of densities is

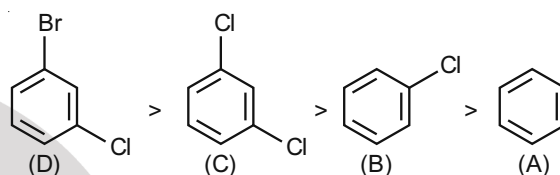

3. Match List-I with List-II :

List-I Elements	List-II Properties
(a) Li	(i) Poor water solubility of I <sup>-</sup> salt
(b) Na	(ii) Most abundant element in cell fluid
(c) K	(iii) Bicarbonate salt used in fire extinguisher
(d) Cs	(iv) Carbonate salt decomposes easily on heating

Choose the correct answer from the options given below :

- (1) (a) - (i), (b) - (iii), (c) - (ii), (d) - (iv)
- (2) (a) - (i), (b) - (ii), (c) - (iii), (d) - (iv)
- (3) (a) - (iv), (b) - (iii), (c) - (ii), (d) - (i)
- (4) (a) - (iv), (b) - (ii), (c) - (iii), (d) - (i)

**Answer (3)**

**Sol.** Among alkali metals and their compounds Li<sub>2</sub>CO<sub>3</sub> is thermally least stable and decomposes easily on heating

NaHCO<sub>3</sub> is used as fire extinguisher

K is most abundant element in cell fluid

CsI is a covalent compound and has poor water solubility

∴ Correct answer

- (a) - (iv), (b) - (iii), (c) - (ii), (d) - (i)

4. Match List-I with List-II :

List-I Example of Colloids	List-II Classification
(a) Cheese	(i) Dispersion of liquid in liquid
(b) Pumice stone	(ii) Dispersion of liquid in gas
(c) Hair cream	(iii) Dispersion of gas in solid
(d) Cloud	(iv) Dispersion of liquid in solid

Choose the most appropriate answer from the options given below :

- (1) (a) - (iv), (b) - (iii), (c) - (i), (d) - (ii)  
 (2) (a) - (iv), (b) - (i), (c) - (iii), (d) - (ii)  
 (3) (a) - (iii), (b) - (iv), (c) - (i), (d) - (ii)  
 (4) (a) - (iv), (b) - (iii), (c) - (ii), (d) - (i)

**Answer (1)**

<b>Sol.</b> Cheese	–	Liquid dispersed in solid
Pumice stone	–	Gas dispersed in solid
Hair cream	–	Liquid dispersed in liquid
Cloud	–	Liquid dispersed in gas

∴ Correct answer is

- (a) - (iv), (b) - (iii), (c) - (i), (d) - (ii)

5. The ionic radii of  $F^-$  and  $O^{2-}$  respectively are 1.33 Å and 1.4 Å, while the covalent radius of N is 0.74 Å.

The correct statement for the ionic radius of  $N^{3-}$  from the following is :

- (1) It is smaller than  $O^{2-}$  and  $F^-$ , but bigger than of N  
 (2) It is bigger than  $F^-$  and N, but smaller than of  $O^{2-}$   
 (3) It is bigger than  $O^{2-}$  and  $F^-$   
 (4) It is smaller than  $F^-$  and N

**Answer (3)**

**Sol.** For isoelectronic species, as the charge on nucleus increases, the ionic radius decreases  $F^-$ ,  $O^{2-}$  and  $N^{3-}$  has 10 electrons each. The decreasing order of their ionic radii is

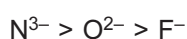

∴  $N^{3-}$  is bigger than both  $O^{2-}$  and  $F^-$

6. What is the major product "P" of the following reaction ?

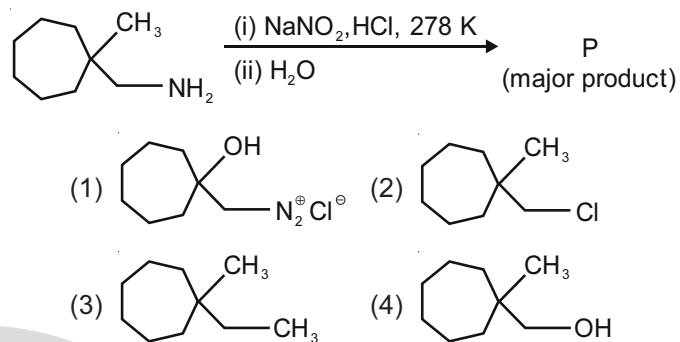

**Answer (4)**

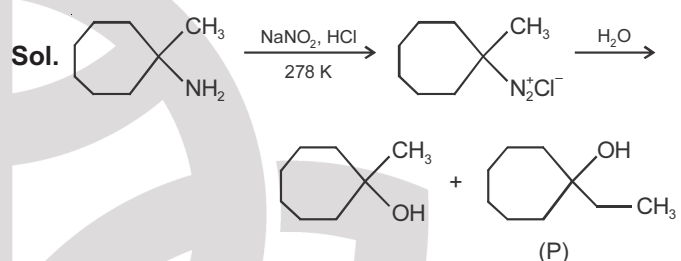

In this reaction major product (P) is a tertiary alcohol formed due to rearrangement of carbocation. But option (4) is one of the products formed though it is not the major product.

7. Which among the following is the strongest acid ?

- (1)   
 (2)   
 (3)  $CH_3CH_2CH_2CH_3$   
 (4)

**Answer (1)**

**Sol.** Cyclopentadiene is the strongest acid as its conjugate base is aromatic.

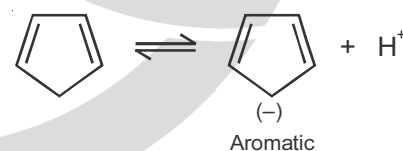

8. Match List-I with List-II : (Both having metallurgical terms)

List-I	List-II
(a) Concentration of Ag ore	(i) Reverberatory furnace
(b) Blast furnace	(ii) Pig iron
(c) Blister copper	(iii) Leaching with dilute NaCN solution
(d) Froth floatation method	(iv) Sulfide ores

Choose the correct answer from the options given below :

- (1) (a) - (iv), (b) - (iii), (c) - (ii), (d) - (i)
- (2) (a) - (iii), (b) - (iv), (c) - (i), (d) - (ii)
- (3) (a) - (iii), (b) - (ii), (c) - (i), (d) - (iv)
- (4) (a) - (iv), (b) - (i), (c) - (iii), (d) - (ii)

**Answer (3)**

**Sol.** Concentration of Ag ore – Leaching with  
dil. NaCN solution

- |                         |                         |
|-------------------------|-------------------------|
| Blast furnace           | – Pig iron              |
| Blister copper          | – Reverberatory furnace |
| Froth floatation method | – Sulphide ores         |

∴ Correct match is

- (a) - (iii), (b) - (ii), (c) - (i), (d) - (iv)

9. The spin only magnetic moments (in BM) for free  $Ti^{3+}$ ,  $V^{2+}$  and  $Sc^{3+}$  ions respectively are

(At. No. Sc : 21 ; Ti : 22 ; V : 23)

- |                   |                   |
|-------------------|-------------------|
| (1) 1.73, 3.87, 0 | (2) 0, 3.87, 1.73 |
| (3) 3.87, 1.73, 0 | (4) 1.73, 0, 3.87 |

**Answer (1)**

**Sol.** The electronic configuration and magnetic moment of the given species are

- $Ti^{3+} : 3d^1 \quad \mu = 1.73 \text{ BM}$   
 $V^{2+} : 3d^3 \quad \mu = 3.87 \text{ BM}$   
 $Sc^{3+} : 3d^0 \quad \mu = 0$

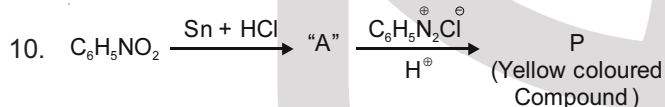

Consider the above reaction, the Product “P” is :

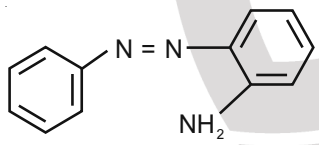
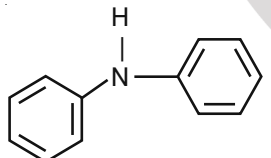
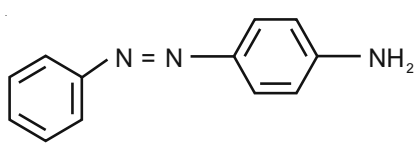
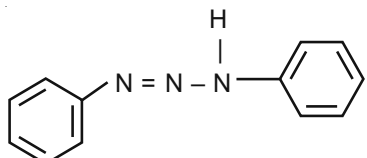
- (1) 
- (2) 
- (3) 
- (4) 

**Answer (3)**

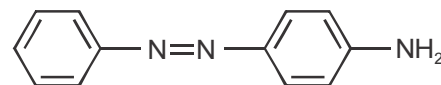
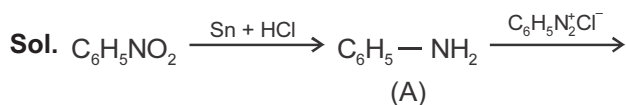

Diazonium cation attacks at the para position of aniline to form azo compound.

11. In the following the correct bond order sequence is :

- (1)  $O_2^+ > O_2^- > O_2^{2-} > O_2$
- (2)  $O_2^+ > O_2 > O_2^- > O_2^{2-}$
- (3)  $O_2^{2-} > O_2^+ > O_2^- > O_2$
- (4)  $O_2 > O_2^- > O_2^{2-} > O_2^+$

**Answer (2)**

**Sol.** Electronic configuration and B and order of the given species

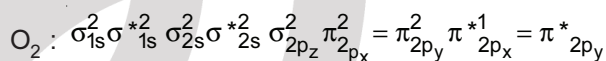

B.O. = 2

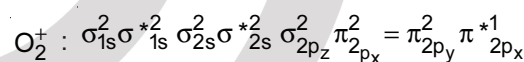

B.O. = 2.5

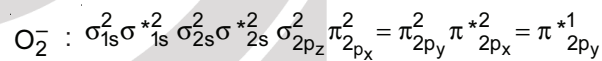

B.O. = 1.5

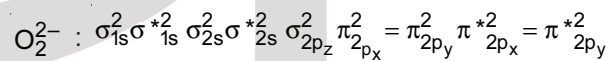

B.O. = 1.0

∴ Correct bond order sequence is

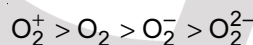

12. Identify the process in which change in the oxidation state is five :

- |   |                                      |
|---|--------------------------------------|
| (1) $C_2O_4^{2-} \rightarrow 2CO_2$     | (2) $MnO_4^- \rightarrow Mn^{2+}$    |
| (3) $Cr_2O_7^{2-} \rightarrow 2Cr^{3+}$ | (4) $CrO_4^{2-} \rightarrow Cr^{3+}$ |

**Answer (2)**

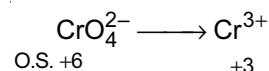
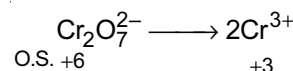
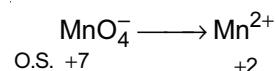
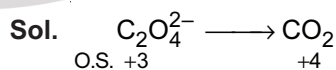

13. A biodegradable polyamide can be made from :

- (1) Glycine and isoprene
- (2) Glycine and aminocaproic acid
- (3) Styrene and caproic acid
- (4) Hexamethylene diamine and adipic acid

**Answer (2)**

**Sol.** Glycine and aminocaproic acid undergo condensation polymerisation to form Nylon-2-nylon-6, a biodegradable polymer.

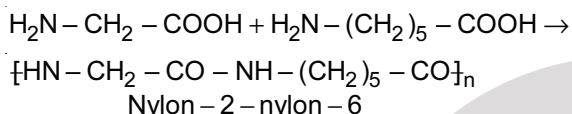

14. Which one of the following metal complexes is most stable ?

- (1)  $[\text{Co}(\text{NH}_3)_6]\text{Cl}_2$
- (2)  $[\text{Co}(\text{en})(\text{NH}_3)_4]\text{Cl}_2$
- (3)  $[\text{Co}(\text{en})_2(\text{NH}_3)_2]\text{Cl}_2$
- (4)  $[\text{Co}(\text{en})_3]\text{Cl}_2$

**Answer (4)**

**Sol.** Cyclic complexes, called chelates, are generally more stable than open chain complexes. Chelates having more number of cyclic rings are more stable than those having less number of cyclic rings.

∴ Of the given complexes  $[\text{Co}(\text{en})_3]\text{Cl}_2$  is most stable.

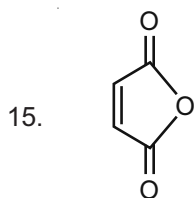
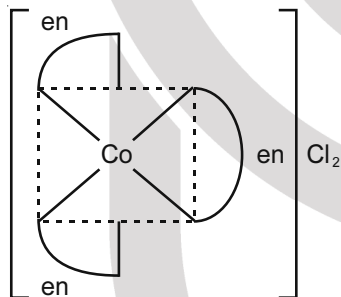

Maleic anhydride

Maleic anhydride can be prepared by :

- (1) Treating cis-but-2-enedioic acid with alcohol and acid
- (2) Heating cis-but-2-enedioic acid
- (3) Treating trans-but-2-enedioic acid with alcohol and acid
- (4) Heating trans-but-2-enedioic acid

**Answer (2)**

**Sol.** Maleic anhydride can be prepared by heating cis-but-2-enedioic acid

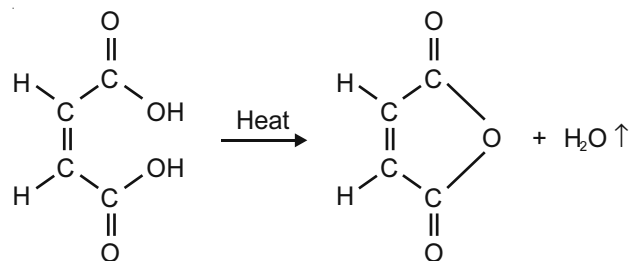

16. Identify the species having one  $\pi$ -bond and maximum number of canonical forms from the following :

- (1)  $\text{SO}_2$
- (2)  $\text{O}_2$
- (3)  $\text{CO}_3^{2-}$
- (4)  $\text{SO}_3$

**Answer (3)**

**Sol.**  $\text{SO}_2$

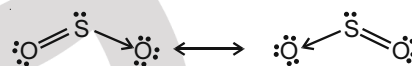

Two canonical forms

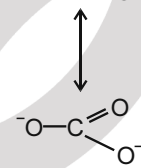
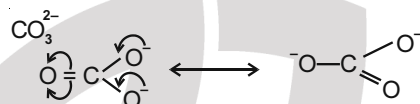

Three canonical forms

17. Which one of the following metals forms interstitial hydride easily ?

- (1) Mn
- (2) Cr
- (3) Fe
- (4) Co

**Answer (2)**

**Sol.** Cr has tendency to form hydride easily

Elements of group - 7 and 8 do not form hydrides

18. Which one of the following is correct structure for cytosine ?

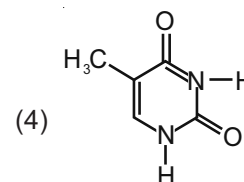
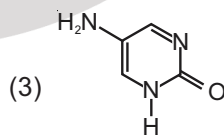
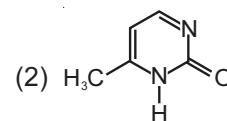
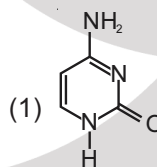

**Answer (1)**

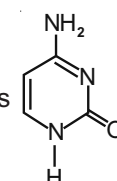
**Sol.** Cytosine is 

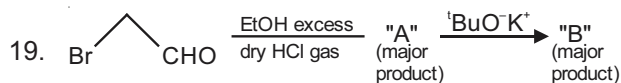

[where Et  $\Rightarrow$   $-\text{C}_2\text{H}_5$  tBu  $\Rightarrow$   $(\text{CH}_3)_3\text{C}-$ ]

Consider the above reaction sequence, Product "A" and Product "B" formed respectively are :

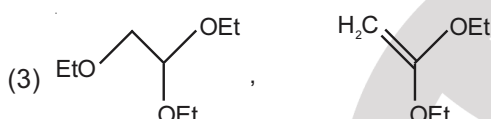
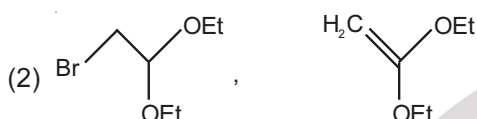
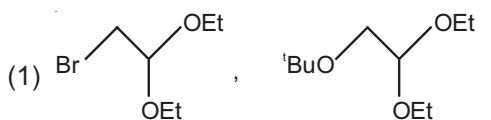

**Answer (2)**

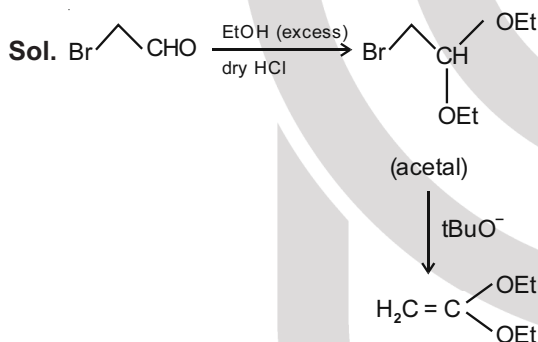

20. A reaction of benzonitrile with one equivalent  $\text{CH}_3\text{MgBr}$  followed by hydrolysis produces a yellow liquid "P". The compound "P" will give positive \_\_\_\_\_.

- (1) Tollen's test                      (2) Schiff's test  
(3) Ninhydrin's test                (4) Iodoform test

**Answer (4)**

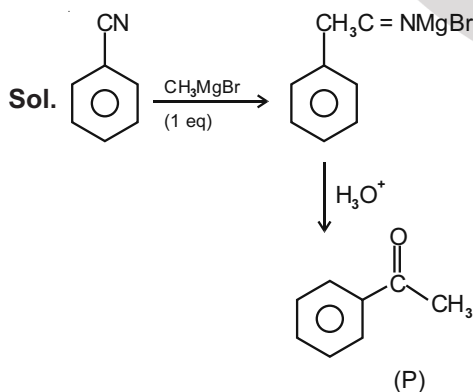

P can give Iodoform test

## SECTION - II

**Numerical Value Type Questions:** This section contains 10 questions. In Section II, attempt any five questions out of 10. The answer to each question is a **NUMERICAL VALUE**. For each question, enter the correct numerical value (in decimal notation, truncated/rounded-off to the second decimal place; e.g. 06.25, 07.00, -00.33, -00.30, 30.27, -27.30) using the mouse and the on-screen virtual numeric keypad in the place designated to enter the answer.

1. The number of significant figures in 0.00340 is \_\_\_\_\_.

**Answer (3)**

**Sol.** The number of significant figures in 0.00340 is three.

2. Assuming that  $\text{Ba}(\text{OH})_2$  is completely ionised in aqueous solution under the given conditions the concentration of  $\text{H}_3\text{O}^+$  ions in 0.005 M aqueous solution of  $\text{Ba}(\text{OH})_2$  at 298 K is \_\_\_\_\_  $\times 10^{-12}$  mol  $\text{L}^{-1}$ . (Nearest integer)

**Answer (1)**

**Sol.**  $\text{Ba}(\text{OH})_2 \rightarrow \text{Ba}^{2+} + 2\text{OH}^-$   
 $[\text{OH}^-] = 2 \times 0.005 = 0.01 \text{ M}$

$$[\text{H}_3\text{O}^+] = \frac{K_w}{[\text{OH}^-]} = \frac{10^{-14}}{0.01} = 10^{-12} = 01.00 \times 10^{-12} \text{ M}$$

3. Number of electrons present in 4f orbital of  $\text{Ho}^{3+}$  ion is \_\_\_\_\_. (Given Atomic No. of Ho = 67)

**Answer (10)**

**Sol.** Electronic configurations of Ho and  $\text{Ho}^{3+}$  are

Ho :  $4f^{11} 6s^2$

$\text{Ho}^{3+}$  :  $4f^{10}$

$\therefore$  Number of electrons present in 4f orbital of  $\text{Ho}^{3+}$  is 10.

4. An LPG cylinder contains gas at a pressure of 300 kPa at  $27^\circ\text{C}$ . The cylinder can withstand the pressure of  $1.2 \times 10^6$  Pa. The room in which the cylinder is kept catches fire. The minimum temperature at which the bursting of cylinder will take place is \_\_\_\_\_  $^\circ\text{C}$ . (Nearest integer)

**Answer (927)**

**Sol.** At constant volume and number of moles of a gas, pressure is directly proportional to temperature

$$\frac{P_1}{T_1} = \frac{P_2}{T_2}$$

$$T_2 = \frac{1.2 \times 10^6}{300 \times 10^3} \times 300 = 1200 \text{ K} = 927^\circ\text{C}$$

5. For a chemical reaction  $A \rightarrow B$ , it was found that concentration of B is increased by  $0.2 \text{ mol L}^{-1}$  in 30 min. The average rate of the reaction is \_\_\_\_\_  $\times 10^{-1} \text{ mol L}^{-1}\text{h}^{-1}$ . (in nearest integer)

**Answer (4)**

**Sol.**  $A \rightarrow B$

$$\begin{aligned} \text{Average rate} &= \frac{\text{Increase in concentration of B}}{\text{Time}} \\ &= \frac{0.2 \text{ mol L}^{-1}}{0.5 \text{ hr}} \\ &= 0.4 = 4 \times 10^{-1} \text{ mol L}^{-1}\text{h}^{-1} \end{aligned}$$

6. An accelerated electron has a speed of  $5 \times 10^6 \text{ ms}^{-1}$  with an uncertainty of 0.02%. The uncertainty in finding its location while in motion is  $x \times 10^{-9} \text{ m}$ . The value of x is \_\_\_\_\_.
- [Use mass of electron =  $9.1 \times 10^{-31} \text{ kg}$ ,  $h = 6.63 \times 10^{-34} \text{ Js}$ ,  $\pi = 3.14$ ]

**Answer (58)**

**Sol.** Uncertainty in speed of electron =  $\frac{0.02}{100} \times 5 \times 10^6$

$$= 10^3 \text{ ms}^{-1}$$

$$m\Delta v \times \Delta x = \frac{h}{4\pi}$$

$$\Delta x = \frac{6.63 \times 10^{-34}}{4 \times 3.14 \times 9.1 \times 10^{-31} \times 10^3}$$

$$= 5.80 \times 10^{-8} \text{ m} = 58.00 \times 10^{-9} \text{ m}$$

7. When 3.00 g of a substance 'X' is dissolved in 100 g of  $\text{CCl}_4$ , it raises the boiling point by 0.60 K. The molar mass of the substance 'X' is \_\_\_\_\_  $\text{g mol}^{-1}$ . (Nearest integer)
- [Given  $K_b$  for  $\text{CCl}_4$  is  $5.0 \text{ K kg mol}^{-1}$ ]

**Answer (250)**

**Sol.**  $\Delta T_b = K_b m$

$$0.60 = \frac{5.0 \times 3.00 \times 1000}{M \times 100}$$

$$M = 250$$

$$\text{Molecular weight of the substance} = 250$$

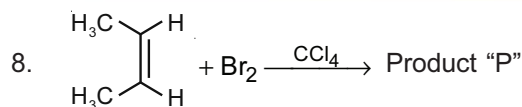

Consider the above chemical reaction. The total number of stereoisomers possible for Product 'P' is \_\_\_\_\_.

**Answer (2)**

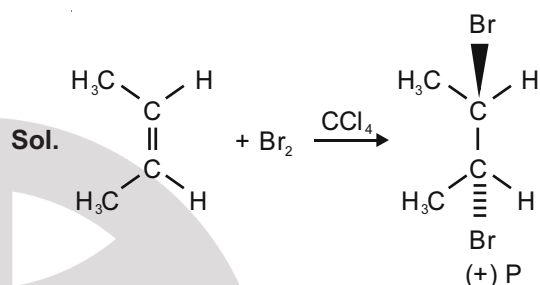

Addition of  $\text{Br}_2$  to alkene is anti addition.

Two stereoisomers are formed in the given reaction.

9. 0.8 g of an organic compound was analysed by Kjeldahl's method for the estimation of nitrogen. If the percentage of nitrogen in the compound was found to be 42%, then \_\_\_\_\_ mL of 1 M  $\text{H}_2\text{SO}_4$  would have been neutralized by the ammonia evolved during the analysis.

**Answer (12)**

**Sol.** wt of N in given organic compound

$$= \frac{0.8 \times 42}{100} = 0.336 \text{ g}$$

$$\text{moles of N} = \text{moles of NH}_3$$

$$= 0.024$$

$$\therefore N_1 V_1 = N_2 V_2$$

$$(\text{NH}_3) \quad (\text{H}_2\text{SO}_4)$$

$$0.024 = 2 \times 1 \times \frac{V}{1000}$$

$$V = 12$$

10. A system does 200 J of work and at the same time absorbs 150 J of heat. The magnitude of the change in internal energy is \_\_\_\_\_ J. (Nearest integer)

**Answer (50)**

**Sol.**  $\Delta U = q + w$  (according first law of thermodynamics)

$$= 150 - 200$$

$$= -50 \text{ J}$$

## PART-C : MATHEMATICS

### SECTION - I

**Multiple Choice Questions:** This section contains 20 multiple choice questions. Each question has 4 choices (1), (2), (3) and (4), out of which **ONLY ONE** is correct.

**Choose the correct answer :**

1. The number of real solutions of the equation,  $x^2 - |x| - 12 = 0$  is

- (1) 4  
(2) 2  
(3) 1  
(4) 3

**Answer (2)**

**Sol.**  $x^2 - |x| - 12 = 0$   
 $x^2 - 4|x| + 3|x| - 12 = 0$   
 $(|x| - 4)(|x| + 3) = 0$   
 $|x| = 4$  or  $-3$  (rejected)  
 $x = \pm 4$  2 solutions

2. The value of the integral  $\int_{-1}^1 \log(x + \sqrt{x^2 + 1}) dx$  is

- (1) 0  
(2) -1  
(3) 2  
(4) 1

**Answer (1)**

**Sol.** Let  $I = \int_{-1}^1 \log(x + \sqrt{x^2 + 1}) dx$

As  $f(x)$  is odd,  $\int_{-a}^a f(x) = 0$

$\therefore I = 0$

3. If  $f(x) = \begin{cases} \int_0^x (5 + |1-t|) dt, & x > 2 \\ 5x + 1, & x \leq 2 \end{cases}$ , then

- (1)  $f(x)$  is everywhere differentiable  
 (2)  $f(x)$  is not continuous at  $x = 2$   
 (3)  $f(x)$  is not differentiable at  $x = 1$   
 (4)  $f(x)$  is continuous but not differentiable at  $x = 2$

**Answer (4)**

**Sol.**  $\lim_{x \rightarrow 2^-} f(x) = \int_0^2 (5 + |1-t|) dt$   
 $= \int_0^1 (5 + 1-t) dt + \int_1^2 (5 + t - 1) dt$   
 $= 6t - \frac{t^2}{2} \Big|_0^1 + 4t + \frac{t^2}{2} \Big|_1^2$   
 $= 6 - \frac{1}{2} + \left( 8 + 2 - 4 - \frac{1}{2} \right)$   
 $= 16 - 4 - 1 = 11 = \lim_{x \rightarrow 2^+} f(x) = f(2)$

at  $x = 2$  (checking differentiability)

LHD =  $\lim_{h \rightarrow 0^-} \frac{f(2-h) - f(2)}{-h} = \lim_{h \rightarrow 0^-} \frac{5(2-h) + 1 - 11}{-h} = 5$

RHD =  $\lim_{h \rightarrow 0^+} \frac{f(2+h) - f(2)}{h} = \lim_{h \rightarrow 0^+} \frac{\int_0^{2+h} (5 + |1-t|) dt - 11}{h}$   
 $= \lim_{h \rightarrow 0^+} \frac{5 + |1 - (2+h)|}{h} = 6$

$\therefore f(x)$  is continuous and non-differentiable

4. Let the equation of the pair of lines,  $y = px$  and  $y = qx$ , can be written as  $(y - px)(y - qx) = 0$ . Then the equation of the pair of the angle bisectors of the lines  $x^2 - 4xy - 5y^2 = 0$  is

- (1)  $x^2 - 3xy + y^2 = 0$   
 (2)  $x^2 + 3xy - y^2 = 0$   
 (3)  $x^2 - 3xy - y^2 = 0$   
 (4)  $x^2 + 4xy - y^2 = 0$

**Answer (2)**

**Sol.** Pair of bisector for  $ax^2 + 2hxy + by^2 = 0$  are

$$\frac{x^2 - y^2}{a - b} = \frac{xy}{h}$$

$\therefore$  for  $x^2 - 4xy - 5y^2 = 0$  are

$$\frac{x^2 - y^2}{1 + 5} = \frac{xy}{-2}$$

$$\Rightarrow -x^2 + y^2 - 3xy = 0$$

$$\Rightarrow x^2 - y^2 + 3xy = 0$$

5. If the greatest value of the term independent of 'x' in the expansion of  $\left(x \sin \alpha + a \frac{\cos \alpha}{x}\right)^{10}$  is  $\frac{10!}{(5!)^2}$ , then the value of 'a' is equal to
- (1) -1                                      (2) -2  
 (3) 2                                        (4) 1

**Answer (3)**

**Sol.**  $T_{r+1} = {}^{10}C_r (x \sin \alpha)^{10-r} \left(\frac{a \cos \alpha}{x}\right)^r$

r = 5 for term independent of x

$$\therefore {}^{10}C_5 \sin^5 \alpha a^5 \cos^5 \alpha = \frac{10!}{(5!)^2}$$

$$\therefore \frac{a^5}{2^5} \sin^5 2\alpha = 1$$

For greatest value to occur  $\sin 2\alpha = 1$

$$\text{and } \frac{a^5}{2^5} = 1 \Rightarrow a = 2$$

6. Let X be a random variable such that the probability function of a distribution is given by  $P(X=0) = \frac{1}{2}$ ,

$P(X=j) = \frac{1}{3^j}$  ( $j=1, 2, 3, \dots, \infty$ ). Then the mean of the distribution and P(X is positive and even) respectively are

- (1)  $\frac{3}{4}$  and  $\frac{1}{9}$                               (2)  $\frac{3}{4}$  and  $\frac{1}{16}$   
 (3)  $\frac{3}{4}$  and  $\frac{1}{8}$                                 (4)  $\frac{3}{8}$  and  $\frac{1}{8}$

**Answer (3)**

**Sol.** Mean =  $\sum x_i p_i$

$$= 0\left(\frac{1}{2}\right) + 1\left(\frac{1}{3}\right) + 2\left(\frac{1}{3^2}\right) + 3\left(\frac{1}{3^3}\right) + \dots$$

$$S = \frac{1}{3} + 2\left(\frac{1}{3^2}\right) + 3\left(\frac{1}{3^3}\right) + \dots \infty$$

$$\frac{S}{3} = \frac{1}{3^2} + 2\left(\frac{1}{3^3}\right) + \dots$$

---

$$\frac{2S}{3} = \frac{1}{3} + \frac{1}{3^2} + \frac{1}{3^3} + \dots \infty$$

$$\frac{2S}{3} = \frac{1}{3} \Rightarrow \frac{2S}{3} = \frac{1}{2}$$

$$\Rightarrow S = \frac{3}{4}$$

$$\text{Mean} = \frac{3}{4}$$

P(X is positive and even) can be  $\frac{1}{3^2}, \frac{1}{3^4}, \frac{1}{3^6}, \dots$

P(X is positive and even)

$$= \frac{1}{3^2} + \frac{1}{3^4} + \frac{1}{3^6} + \dots = \frac{1}{8}$$

7. The lowest integer which is greater than

$$\left(1 + \frac{1}{10^{100}}\right)^{10^{100}}$$
 is \_\_\_\_\_.

- (1) 1    (2) 4  
 (3) 3    (4) 2

**Answer (3)**

**Sol.** Let  $10^{100} = x$

$$\left(1 + \frac{1}{x}\right)^x \in (2, e)$$

Hence lowest integer 3

8. Let  $y = y(x)$  be the solution of the differential equation  $x dy = (y + x^3 \cos x) dx$  with  $y(\pi) = 0$ , then

$y\left(\frac{\pi}{2}\right)$  is equal to

- (1)  $\frac{\pi^2}{2} + \frac{\pi}{4}$                                       (2)  $\frac{\pi^2}{2} - \frac{\pi}{4}$   
 (3)  $\frac{\pi^2}{4} - \frac{\pi}{2}$                                       (4)  $\frac{\pi^2}{4} + \frac{\pi}{2}$

**Answer (4)**

**Sol.**  $\frac{x dy - y dx}{x^2} = x \cos x dx$

$$\int d\left(\frac{y}{x}\right) = \int x \cos x dx$$

$$\Rightarrow \frac{y}{x} = x \sin x + \cos x + c$$

$$\downarrow y(\pi) = 0 \Rightarrow c = 1$$

$$\Rightarrow y = x^2 \sin x + x \cos x + x$$

$$y\left(\frac{\pi}{2}\right) = \frac{\pi^2}{4} + \frac{\pi}{2}$$



9. The sum of all those terms which are rational numbers in the expansion of  $(2^{1/3} + 2^{1/4})^{12}$  is

- (1) 43 (2) 27  
(3) 35 (4) 89

**Answer (1)**

**Sol.** The general term of  $(2^{1/3} + 2^{1/4})^{12}$  is

$$T_{r+1} = {}^{12}C_r 2^{\frac{12-r}{3}} \cdot 2^{\frac{r}{4}}$$

For rational terms  $r = 0$  and  $12$ .

$$\begin{aligned} \therefore \text{Sum of rational terms} &= {}^{12}C_0 \cdot 2^4 \cdot 3^0 + {}^{12}C_{12} \cdot 2^0 \cdot 3^3 \\ &= 16 + 27 \\ &= 43 \end{aligned}$$

10. Let  $a, b$  and  $c$  be distinct positive numbers. If the vectors  $a\hat{i} + a\hat{j} + c\hat{k}, \hat{i} + \hat{k}$  and  $c\hat{i} + c\hat{j} + b\hat{k}$  are co-planar, then  $c$  is equal to

- (1)  $\frac{2}{\frac{1}{a} + \frac{1}{b}}$  (2)  $\sqrt{ab}$   
(3)  $\frac{a+b}{2}$  (4)  $\frac{1}{\frac{1}{a} + \frac{1}{b}}$

**Answer (2)**

**Sol.**  $\therefore a\hat{i} + a\hat{j} + c\hat{k}, \hat{i} + \hat{k}$  and  $c\hat{i} + c\hat{j} + b\hat{k}$  are co-planar.

$$\therefore \begin{vmatrix} a & a & c \\ 1 & 0 & 1 \\ c & c & b \end{vmatrix} = 0$$

$$\therefore \begin{vmatrix} a-c & a & c \\ 0 & 0 & 1 \\ c-b & c & b \end{vmatrix} = 0$$

$$\therefore (-1) \{ac - c^2 - ca + ab\} = 0$$

$$\therefore c^2 = ab$$

$$\therefore c = \sqrt{ab}$$

11. Consider functions  $f : A \rightarrow B$  and  $g : B \rightarrow C$  ( $A, B, C \subseteq \mathbb{R}$ ) such that  $(gof)^{-1}$  exists, then

- (1)  $f$  is one-one and  $g$  is onto  
(2)  $f$  is onto and  $g$  is one-one  
(3)  $f$  and  $g$  both are one-one  
(4)  $f$  and  $g$  both are onto

**Answer (1)**

**Sol.**  $\therefore f : A \rightarrow B$  and  $g : B \rightarrow C$  then  $(gof)^{-1} = f^{-1} \circ g^{-1}$

$$\therefore f^{-1} : B \rightarrow A \text{ and } g^{-1} : C \rightarrow B$$

$$\therefore (gof)^{-1} : C \rightarrow A$$

$\therefore f$  must be one-one and  $g$  will be onto function.

12. The value of  $\cot \frac{\pi}{24}$  is

- (1)  $3\sqrt{2} - \sqrt{3} - \sqrt{6}$   
(2)  $\sqrt{2} - \sqrt{3} - 2 + \sqrt{6}$   
(3)  $\sqrt{2} + \sqrt{3} + 2 - \sqrt{6}$   
(4)  $\sqrt{2} + \sqrt{3} + 2 + \sqrt{6}$

**Answer (4)**

$$\begin{aligned} \text{Sol. } \cot \frac{\pi}{24} &= \frac{2 \cos \frac{\pi}{24} \cdot \sin \frac{\pi}{24}}{2 \sin \frac{\pi}{24} \cdot \sin \frac{\pi}{24}} \\ &= \frac{\sin \frac{\pi}{12}}{1 - \cos \frac{\pi}{12}} = \frac{\frac{\sqrt{3}-1}{2\sqrt{2}}}{1 - \frac{\sqrt{3}+1}{2\sqrt{2}}} \\ &= \frac{\sqrt{3}-1}{2\sqrt{2}-\sqrt{3}-1} \times \frac{2\sqrt{2}+\sqrt{3}+1}{2\sqrt{2}+\sqrt{3}+1} \\ &= \frac{2\sqrt{6}+3+\sqrt{3}-2\sqrt{2}-\sqrt{3}-1}{8-(3+1+2\sqrt{3})} \\ &= \frac{\sqrt{6}-\sqrt{2}+1}{2-\sqrt{3}} \times \frac{2+\sqrt{3}}{2+\sqrt{3}} \\ &= 2\sqrt{6}+3\sqrt{2}-2\sqrt{2}-\sqrt{6}+2+\sqrt{3} \\ &= \sqrt{6}+\sqrt{2}+2+\sqrt{3} \\ &= \sqrt{2}+\sqrt{3}+2+\sqrt{6} \end{aligned}$$

13. The number of distinct real roots of

$$\begin{vmatrix} \sin x & \cos x & \cos x \\ \cos x & \sin x & \cos x \\ \cos x & \cos x & \sin x \end{vmatrix} = 0 \text{ in the interval}$$

$$-\frac{\pi}{4} \leq x \leq \frac{\pi}{4} \text{ is}$$

- (1) 2 (2) 1  
(3) 4 (4) 3

**Answer (1)**

**Sol.** 
$$\begin{vmatrix} \sin x & \cos x & \cos x \\ \cos x & \sin x & \cos x \\ \cos x & \cos x & \sin x \end{vmatrix} = 0$$

$$\begin{vmatrix} \sin x + 2\cos x & \cos x & \cos x \\ \sin x + 2\cos x & \sin x & \cos x \\ \sin x + 2\cos x & \cos x & \sin x \end{vmatrix} = 0$$

$$(\sin x + 2\cos x) \begin{vmatrix} 0 & \cos x - \sin x & 0 \\ 0 & \sin x - \cos x & \cos x - \sin x \\ 1 & \cos x & \sin x \end{vmatrix} = 0$$

$$\therefore (\sin x + 2\cos x)(\cos x - \sin x)^2 = 0$$

$$\therefore \tan x = -2 \text{ and } \tan x = 1$$

$$\therefore \text{Number of roots in } x \in \left[-\frac{\pi}{4}, \frac{\pi}{4}\right] \text{ is 1.}$$

14. If  ${}^n P_r = {}^n P_{r+1}$  and  ${}^n C_r = {}^n C_{r-1}$  then the value of r is equal to

- (1) 4 (2) 3  
(3) 2 (4) 1

**Answer (3)**

**Sol.**  ${}^n P_r = {}^n P_{r+1}$

$$\Rightarrow \frac{n!}{(n-r)!} = \frac{n!}{(n-r-1)!}$$

$$\therefore (n-r) \cdot (n-r-1)! = (n-r-1)!$$

$$\therefore (n-r-1)!(n-r-1) = 0$$

$$\therefore n-r-1 = 0 \quad \dots(i)$$

$${}^n C_r = {}^n C_{r-1}$$

$$\Rightarrow \frac{n!}{r!(n-r)!} = \frac{n!}{(n-r+1)!(r-1)!}$$

$$\Rightarrow r = n - r + 1$$

$$n - 2r = -1 \quad \dots(ii)$$

From (i) and (ii) :  $r = 2, n = 3$

15. If  $|\vec{a}| = 2, |\vec{b}| = 5$  and  $|\vec{a} \times \vec{b}| = 8$ , then  $|\vec{a} \cdot \vec{b}|$  is equal to

- (1) 3  
(2) 6  
(3) 4  
(4) 5

**Answer (2)**

**Sol.**  $|\vec{a}| = 2, |\vec{b}| = 5, |\vec{a} \times \vec{b}| = 8$

$$\therefore |\vec{a} \times \vec{b}|^2 = |\vec{a}|^2 |\vec{b}|^2 - (\vec{a} \cdot \vec{b})^2$$

$$\begin{aligned} \therefore (\vec{a} \cdot \vec{b})^2 &= 5^2 \cdot 2^2 - 8^2 \\ &= 100 - 64 \\ &= 36 \end{aligned}$$

$$\therefore \vec{a} \cdot \vec{b} = \pm 6$$

16. Consider the statement "The match will be played only if the weather is good and ground is not wet". Select the correct negation from the following

- (1) The match will not be played or weather is good and ground is not wet  
(2) The match will be played and weather is not good or ground is wet  
(3) The match will not be played and weather is not good and ground is wet  
(4) If the match will not be played, then either weather is not good or ground is wet

**Answer (2)**

**Sol.** Consider the statements,

m : match will be played

w : weather is good

g : ground is not wet

$\therefore p : m \leftrightarrow (w \wedge g) \Rightarrow$  In Venn diagram it will be represented by  $[m \Delta (w \cap g)]^c$

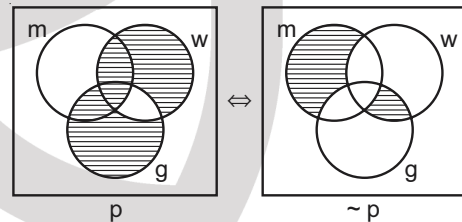

So  $\sim p : m \wedge (\sim w \vee \sim g)$  also  $\sim p : (w \wedge g) \wedge (\sim m)$   
 $\Rightarrow \sim p : \text{match will be played and weather is not good or ground is wet.}$

17. If  $[x]$  be the greatest integer less than or equal to

$$x, \text{ then } \sum_{n=8}^{100} \left[ \frac{(-1)^n n}{2} \right] \text{ is equal to}$$

- (1) 2 (2) -2  
(3) 0 (4) 4

**Answer (4)**

**Sol.** 
$$\sum_{n=8}^{100} \left[ \frac{(-1)^n n}{2} \right] = 4 - 5 + 5 - 6 + 6 - 7 + 7 + \dots - 50 + 50$$
  
$$= 4$$

18. If  $P = \begin{bmatrix} 1 & 0 \\ \frac{1}{2} & 1 \end{bmatrix}$ , then  $P^{50}$  is

(1)  $\begin{bmatrix} 1 & 25 \\ 0 & 1 \end{bmatrix}$                       (2)  $\begin{bmatrix} 1 & 0 \\ 50 & 1 \end{bmatrix}$

(3)  $\begin{bmatrix} 1 & 0 \\ 25 & 1 \end{bmatrix}$                       (4)  $\begin{bmatrix} 1 & 50 \\ 0 & 1 \end{bmatrix}$

**Answer (3)**

**Sol.**  $P^2 = \begin{bmatrix} 1 & 0 \\ 1 & 1 \end{bmatrix}$

$$P^3 = \begin{bmatrix} 1 & 0 \\ \frac{3}{2} & 1 \end{bmatrix}$$

$$\Rightarrow P^n = \begin{bmatrix} 1 & 0 \\ \frac{n}{2} & 1 \end{bmatrix}$$

19. If a tangent to the ellipse  $x^2 + 4y^2 = 4$  meets the tangents at the extremities of its major axis at B and C, then the circle with BC as diameter passes through the point

(1)  $(-1, 1)$

(2)  $(\sqrt{3}, 0)$

(3)  $(1, 1)$

(4)  $(\sqrt{2}, 0)$

**Answer (2)**

**Sol.** Tangent at  $(a\cos\theta, b\sin\theta)$  is

$$\frac{x}{a}\cos\theta + \frac{y}{b}\sin\theta = 1, (a = 2, b = 1)$$

$$x = a \rightarrow y = b \tan \frac{\theta}{2}, A\left(a, b \tan \frac{\theta}{2}\right)$$

$$x = -a \rightarrow y = b \cot \frac{\theta}{2}, B\left(-a, b \cot \frac{\theta}{2}\right)$$

Equations of circle

$$(x - a)(x + a) + \left(y - b \tan \frac{\theta}{2}\right)\left(y - b \cot \frac{\theta}{2}\right) = 0$$

This passes through  $(\sqrt{3}, 0)$

20. The first of the two samples in group has 100 items with mean 15 and standard deviation 3. If the whole group has 250 items with mean 15.6 and standard deviation  $\sqrt{13.44}$ , then the standard deviation of the second sample is

(1) 5                                      (2) 6

(3) 4                                      (4) 8

**Answer (3)**

**Sol.**  $n_1 = 100, n_2 = 150,$

$$(n_1 + n_2)\bar{x} = n_1\bar{x}_1 + n_2\bar{x}_2$$

$$250 \times 15.6 = 100 \times 15 + 150 \times \bar{x}_2$$

$$\bar{x}_2 = 16 \quad d_1^2 = (\bar{x} - \bar{x}_1)^2 = 0.36$$

$$(n_1 + n_2)\sigma^2 = n_1(\sigma_1^2 + d_1^2) + n_2(\sigma_2^2 + d_2^2)$$

$$250 \times 13.44 = 100(9.36) + 150(\sigma_2^2 + 0.16)$$

$$\sigma_2^2 = 16$$

## SECTION - II

**Numerical Value Type Questions:** This section contains 10 questions. In Section II, attempt any five questions out of 10. The answer to each question is a **NUMERICAL VALUE**. For each question, enter the correct numerical value (in decimal notation, truncated/rounded-off to the second decimal place; e.g. 06.25, 07.00, -00.33, -00.30, 30.27, -27.30) using the mouse and the on-screen virtual numeric keypad in the place designated to enter the answer.

1. Consider the function  $f(x) = \frac{P(x)}{\sin(x-2)}$ ,  $x \neq 2$   
 $= 7$ ,  $x = 2$

where  $P(x)$  is a polynomial such that  $P''(x)$  is always a constant and  $P(3) = 9$ . If  $f(x)$  is continuous at  $x = 2$ , then  $P(5)$  is equal to\_\_\_\_\_.

**Answer (39)**

**Sol.**  $P(x) = (x - 2)(ax + b)$

$$\lim_{x \rightarrow 2} P(x) = 7 \Rightarrow 2a + b = 7$$

$$P(3) = 9 \Rightarrow 3a + b = 9$$

$$a = 2, b = 3$$

$$P(x) = (x - 2)(2x + 3)$$

$$P(5) = 39$$

2. If the co-efficients of  $x^7$  and  $x^8$  in the expansion of

$\left(2 + \frac{x}{3}\right)^n$  are equal, then the value of  $n$  is equal to \_\_\_\_\_.

**Answer (55)**

**Sol.**  ${}^n C_7 \cdot 2^{n-7} \times \frac{1}{3^7} = {}^n C_8 \cdot 2^{n-8} \times \frac{1}{3^8}$

$$\frac{{}^n C_8}{{}^n C_7} = 6$$

$$\frac{n-8+1}{8} = 6$$

$$n = 55$$

3. If  $a + b + c = 1$ ,  $ab + bc + ca = 2$  and  $abc = 3$ , then the value of  $a^4 + b^4 + c^4$  is equal to \_\_\_\_\_.

**Answer (13)**

**Sol.**  $\therefore a^2 + b^2 + c^2 = (a + b + c)^2 - 2(ab + bc + ca)$

$$= 1 - 4 = -3$$

and  $a^2b^2 + b^2c^2 + c^2a^2 = (ab + bc + ca)^2$

$$- 2abc(a + b + c) = 4 - 6 = -2$$

So  $a^4 + b^4 + c^4 = (a^2 + b^2 + c^2)$

$$- 2(a^2b^2 + b^2c^2 + c^2a^2)$$

$$= 9 + 4 = 13$$

4. The equation of a circle is  $\text{Re}(z^2) + 2(\text{Im}(z^2)) + 2\text{Re}(z) = 0$ , where  $z = x + iy$ . A line which passes through the centre of the given circle and the vertex of the parabola,  $x^2 - 6x - y + 13 = 0$ , has  $y$ -intercept equal to \_\_\_\_\_.

**Answer (1)**

**Sol.** Eqn. of circle ;  $(x^2 - y^2) + 2(y^2) + 2x = 0$

$$\Rightarrow x^2 + y^2 + 2x = 0 \text{ has centre } A(-1, 0)$$

Vertex of parabola,  $(x - 3)^2 = (y - 4)$  is  $B(3, 4)$

$AB = y = (x + 1)$  has  $y$ -intercept 1.

5. Let  $n \in \mathbb{N}$  and  $[x]$  denote the greatest integer less than or equal to  $x$ . If the sum of  $(n + 1)$  terms  ${}^n C_0, 3 \cdot {}^n C_1, 5 \cdot {}^n C_2, 7 \cdot {}^n C_3, \dots$  is equal to  $2^{100} \cdot 101$ , then

$$2 \left[ \frac{n-1}{2} \right] \text{ is equal to } \underline{\hspace{2cm}}.$$

**Answer (98)**

**Sol.**  $\therefore \sum_{r=0}^n (2r + 1) {}^n C_r = 2^{100} \cdot 101$

$$\Rightarrow 2n \sum_{r=1}^n {}^{n-1} C_{r-1} + \sum_{r=0}^n {}^n C_r = 101 \cdot 2^{100}$$

$$\Rightarrow 2n \cdot 2^{n-1} + 2^n = 101 \cdot 2^{100}$$

$$\Rightarrow (n + 1) \cdot 2^n = 101 \cdot 2^{100}$$

$$\Rightarrow n = 100$$

6. If a rectangle is inscribed in an equilateral triangle of side length  $2\sqrt{2}$  as shown in the figure, then the square of the largest area of such a rectangle is \_\_\_\_\_.

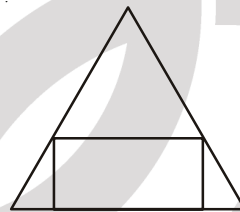

**Answer (3)**

**Sol.** Let the sides of rectangle be  $x$  and  $y$ .

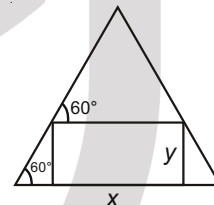

$$\therefore x + \frac{2y}{\sqrt{3}} = 2\sqrt{2}$$

and  $\Delta = xy$

$$\Rightarrow \Delta = y \left( 2\sqrt{2} - \frac{2y}{\sqrt{3}} \right)$$

$$\Rightarrow \Delta = \frac{2}{\sqrt{3}} y (\sqrt{6} - y) \text{ will be maximum if } y = \frac{\sqrt{6}}{2}$$

$$\Rightarrow \Delta_{\max} = \frac{2}{\sqrt{3}} \cdot \frac{\sqrt{6}}{2} \cdot \frac{\sqrt{6}}{2} = \sqrt{3}$$

$$\Rightarrow (\Delta_{\max})^2 = 3$$

7. If  $(\vec{a} + 3\vec{b})$  is perpendicular to  $(7\vec{a} - 5\vec{b})$  and  $(\vec{a} - 4\vec{b})$  is perpendicular to  $(7\vec{a} - 2\vec{b})$ , then the angle between  $\vec{a}$  and  $\vec{b}$  (in degrees) is \_\_\_\_\_.

**Answer (60)**

**Sol.**  $\therefore (\vec{a} + 3\vec{b}) \cdot (7\vec{a} - 5\vec{b}) = 0$

$$\Rightarrow 7|\vec{a}|^2 - 15|\vec{b}|^2 + 16\vec{a} \cdot \vec{b} = 0 \quad \dots(i)$$

and  $(7\vec{a} - 2\vec{b}) \cdot (\vec{a} - 4\vec{b}) = 0$

$$\Rightarrow 7|\vec{a}|^2 + 8|\vec{b}|^2 - 30\vec{a} \cdot \vec{b} = 0 \quad \dots(ii)$$

From (i) and (ii)

$$|\vec{b}|^2 = 2\vec{a} \cdot \vec{b} \text{ and } |\vec{a}|^2 = 2\vec{a} \cdot \vec{b}$$

$$\therefore \vec{a} \cdot \vec{b} = |\vec{a}| |\vec{b}| \cos\theta \Rightarrow \vec{a} \cdot \vec{b} = 2\vec{a} \cdot \vec{b} \cos\theta$$

$$\Rightarrow \cos\theta = \frac{1}{2} \Rightarrow \theta = 60^\circ$$

8. Let a curve  $y = f(x)$  pass through the point  $(2, (\log_e 2)^2)$  and have slope  $\frac{2y}{x \log_e x}$  for all positive real value of  $x$ . Then the value of  $f(e)$  is equal to \_\_\_\_\_.

**Answer (1)**

**Sol.**  $\therefore \frac{dy}{dx} = \frac{2y}{x \ln x} \Rightarrow \frac{dy}{y} = \frac{2dx}{x \ln x}$

$$\Rightarrow \ln y = 2 \ln(\ln x) + C$$

$\therefore (2, (\ln 2)^2)$  lies on the curve, so

$$2 \ln(\ln 2) = 2 \ln(\ln 2) + C \Rightarrow C = 0$$

Now, at  $x = e$

$$\ln y = 0 \Rightarrow y = 1 = f(e)$$

9. A fair coin is tossed  $n$ -times such that the probability of getting at least one head is at least 0.9. Then the minimum value of  $n$  is \_\_\_\_\_.

**Answer (4)**

**Sol.**  $\therefore 1 - \left(\frac{1}{2}\right)^n \geq 0.9$

$$\Rightarrow \frac{1}{2^n} \leq \frac{1}{10} \Rightarrow 2^n \geq 10$$

$$\Rightarrow n \geq 4$$

10. If the lines  $\frac{x-k}{1} = \frac{y-2}{2} = \frac{z-3}{3}$  and  $\frac{x+1}{3} = \frac{y+2}{2} = \frac{z+3}{1}$  are co-planar, then the value of  $k$  is \_\_\_\_\_.

**Answer (1)**

**Sol.**  $\therefore \begin{vmatrix} 1 & 2 & 3 \\ 3 & 2 & 1 \\ k+1 & 4 & 6 \end{vmatrix} = 0$

$$\Rightarrow -4(k+1) - 4(-8) - 4(6) = 0$$

$$\Rightarrow k = 1$$

